



*Let Things Better,  
Faster and Vital*

# User Manual



**iE2P**

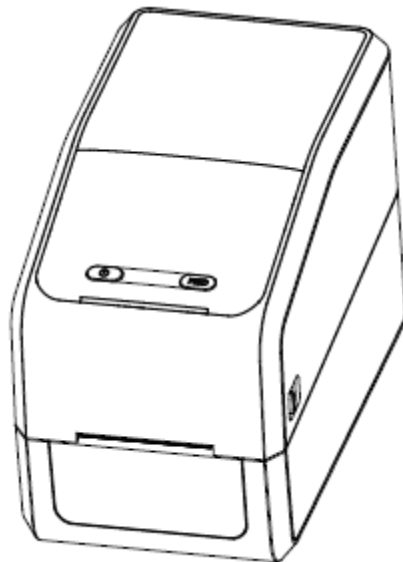

**iE2X**

**Xiamen Hanin Electronic Technology Co., Ltd.**

ADD: 5F, 10#, Aide Airport Industrial Park, Huli District, Xiamen, China

WEB: [www.idprt.com](http://www.idprt.com)

# Contents

Important Safety Instructions.....	1
Chapter 1 Introduction.....	4
1.1 Packing List.....	4
1.2 Appearance and Components.....	5
1.3 Dimension.....	7
Chapter 2 Specifications.....	8
Chapter 3 Installation & Usage.....	10
3.1 Media Loading.....	10
3.1.1 Loading the Roll.....	10
3.1.2 Loading the Ribbon.....	12
3.2 Power Connection.....	14
3.3 Peripherals Connection.....	15
3.3.1 Interface Cable Connection.....	15
3.3.2 Bluetooth Connection.....	15
3.4 Detection.....	16
3.4.1 Continuous Paper.....	16
3.4.2 Labels.....	18
3.4.3 Punched Hole Label.....	20
3.4.4 Blackmark Paper.....	21
3.5 Operation Panel.....	22
3.5.1 Panel Introduction.....	22
3.5.2 Display Operation.....	25
3.5.3 Indicator Instructions.....	27
3.6 Buzzer.....	27
3.7 Basic Function.....	28
3.7.1 Power On/ Power Off.....	28
3.7.2 FEED Button.....	28
3.7.3 Quick Calibration.....	29
3.7.4 Print Self-test Page.....	30
Chapter 4 Interface.....	31
4.1 USB Interface.....	31
4.2 Other Optional Interfaces.....	32
Chapter 5 Maintenance & Adjustment.....	33
5.1 Cleaning Media Sensor.....	33
5.2 Cleaning Thermal Print Head.....	33
5.3 Cleaning Roller and/or Paper Path.....	34
Chapter 6 Printer Utility Tool Instructions.....	35
6.1 Installation Preparation.....	35
6.2 Usage.....	35
Chapter 7 Seagull Windows Driver Instructions.....	53
7.1 Introduction.....	53

---

7.2 Installation Preparation .....	53
7.3 Installation .....	54
7.4 Usage .....	60
7.4.1 Printing Preferences .....	60
7.4.2 Printer Properties .....	74
Chapter 8 BarTender Ultralite Instructions .....	79
8.1 Introduction .....	79
8.2 Installation Preparation .....	79
8.3 Installation .....	80
8.4 Usage .....	84
8.4.1 Page Settings .....	84
8.4.2 label Edit .....	93
Appendix I Display Operation .....	98
Appendix II Warning .....	104
Appendix III Trouble Shooting .....	105
Appendix IV Download Path for Utility and Driver .....	106

---



## ■ Statement

This manual content may be altered without permission, and our company reserves the rights to make changes without notice in technology, spare parts, hardware and software of the products. If more information is needed about the products, please contact our company. Without any written permission from our company, any section of this manual is prohibited to be copied or transferred in any form.

## ■ Copyright

This manual is printed in 2019, the copyright belongs to Xiamen Hanin Electronic Technology Co., Ltd.

Printed in China

1.0 Version

## ■ Warnings



This must be complied with in order to avoid any damage to the human body and the equipment.



This is showing the important information and tips for the printer operation.



**Note: Due to continuous update of our product, the description of printer specification, accessories, design in this manual may be slightly different. Please keep in kind prevail.**

---

# Important Safety Instructions

Before using the appliance, please carefully read the following safety regulations in order to prevent any hazard or material damage.

## 1. Safety warning



Warnings: The print head will become very hot during printing; avoid contact with the print head after printing has finished.



Warnings: Do not touch the printer head and connector in case static damage the printer head.

## 2. Instructions



Warnings: Violating following instructions can cause serious injury or death.

- 1) Do not plug several products in one multiperture outlet.
  - This can provoke over-heating and a fire.
  - If the plug is wet or dirty, dry or wipe it before usage.
  - If the plug does not fit perfectly with the outlet, do not plug in.
  - Be sure to use only standardized multiperture outlet.
- 2) You must use the supplied adapter.
  - It is dangerous to use other adapters.
- 3) Do not pull the cable to unplug.
  - This can damage the cable, which is the origin of a fire or a breakdown of the printer.
- 4) Do not plug in or unplug with your wet hands.
  - You can be electrocuted.
- 5) Do not bend the cable by force or leave it under any heavy object.
  - A damaged cable can cause a fire.



**Note: Violating following instructions may cause slight damage of the appliance.**

- 1) If you observe a strange smoke, odour or noise from the printer, unplug it before taking following measures.
    - Switch off the printer and unplug the set from the mains.
    - After the disappearance of the smoke, call your dealer to repair it.
  
  - 2) Install the printer on the stable surface.
    - If the printer falls, it can be broken and you can hurt yourself.
  
  - 3) Use the approved accessories only and do not try to disassemble, repair or remodel it by yourself.
    - Call your dealer when you need these services.
    - Do not touch the blade of auto cutter.
  
  - 4) Do not let water or other foreign objects drop into the printer.
    - If this happened, switch off and unplug the printer before calling your dealer.
  
  - 5) Do not use the printer when it is out of order. This can cause a fire or an electrocution.
    - Switch off and unplug the printer before calling your dealer.
  
  - 6) Other considerations:
    - Place the printer on a solid and even base so that it cannot fall.
    - Leave enough space around printer for operation and maintenance.
    - Keep all liquids away from the printer.
    - Do not expose the printer to high temperatures, direct sunlight or dust.
    - Ensure the printer is connected to a socket with the correct mains voltage.
    - Switch off the printer POWER supply when it's not in use for a long time.
    - To ensure the printing quality and reliability, suggest use the same quality or recommend paper supplier.
    - Pls. switch off the POWER supply when connect/disconnect all the ports or it will cause damage to the printer control circuit.
    - Never carry out maintenance or repair work yourself. Always contact a qualified service Technician.
    - Keep this User Manual in a place which is always easily accessible.
-

### 3. Other Precautions

The copyright for this user manual and various other manuals is property of our company. Any copying or conversion into electronic form and saving of this material without the express written permission is strictly prohibited. Use of the information contained in this manual is not subject to any patent liability. This manual has been prepared with utmost care and attention to detail but may contain certain errors and/or omissions. Our company is not legally liable for any damages resulting from the use of the information in this manual. Our company and its affiliates are not legally liable (United States excluded) for any damages, loss, costs, and/or expenses that result from the breakdown, malfunction, and/or misuse of the product due to violation or neglect of the operation and maintenance information and instructions provided by our company, as well as from the unauthorized alteration, repair, and/or modification of the product by the user and/or third party. We are not legally liable for any damages and/or issues resulting from the use of options and/or parts that are not authentic or authorized products.

### 4. WEEE (Waste Electrical and Electric Equipment)



This mark shown on the product or its literature indicates that the corresponding item should not be discarded at the end of its working life with other household waste. To prevent possible harm to the environment or human health from uncontrolled waste disposal, please separate marked items from other types of waste and recycle them responsibly to promote the sustained reuse of material resources. Household users should contact either the retailer where they purchased this product, or their local government office for details of where and how they can conduct environmentally safe recycling of such items. Commercial users should contact their suppliers and check the terms and conditions of purchase contracts. This product should not be combined with other commercial waste for disposal.



**Caution: This is a Class A product. In a domestic environment this product may cause radio interference in which the user may be required to take adequate measures.**



# Chapter 1 Introduction

## 1.1 Packing List

1. Unpack the printer and keep the packing material in case you need to ship the printer in the future.
2. Any damages exist, please contact the local dealer.



Printer (e.g. iE2P)

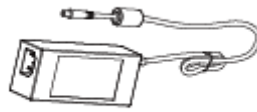

AC Adapter



Power Cord



USB Cable

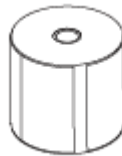

Label Roll



CD



Quick Start Guide



**Note: The packing materials are based on the order.**

## 1.2 Appearance and Components

### ■Front View

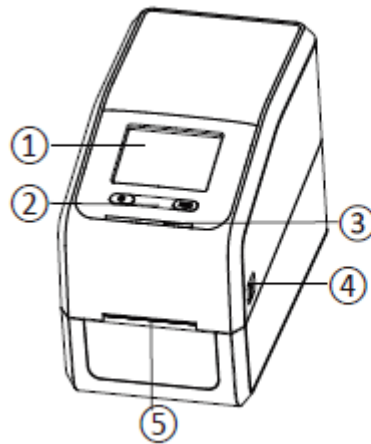

- ① Display
- ② Function Button
- ③ Status Indicator
- ④ Cover Open Levers
- ⑤ Front Paper Outlet

### ■Rear View

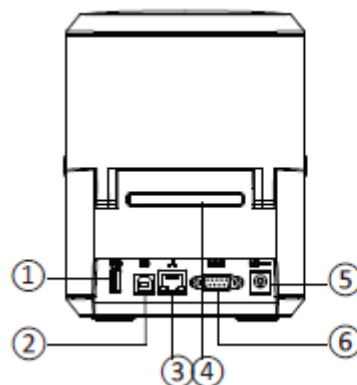

- ① USB Port (Type A)
- ② USB Port (Type B)
- ③ Ethernet Port
- ④ Back Paper Outlet
- ⑤ Power Receptacle
- ⑥ Serial Port

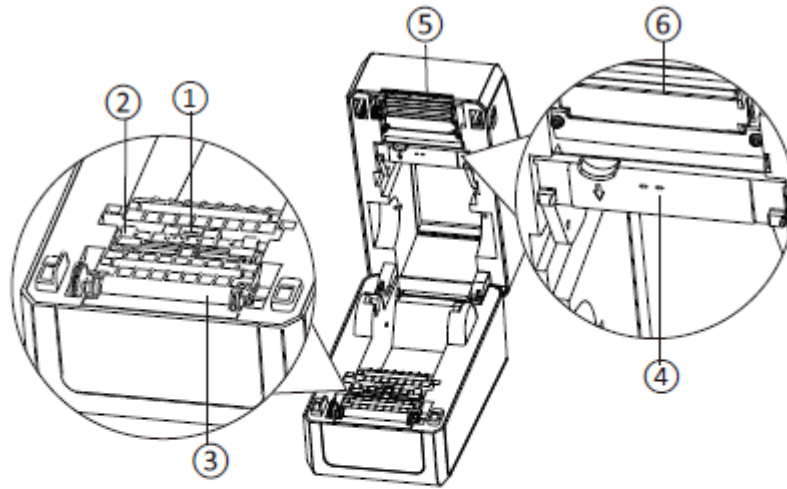
**■ Inside View**

- ① Moveable Label Sensor
- ② Moveable Label Guides
- ③ Platen
- ④ Upper Sensor
- ⑤ Serrated Knife
- ⑥ Print Head Module



**Note:** The views above are for your reference. Ports vary by your choice.

### 1.3 Dimension

Take printer iE2P as example.

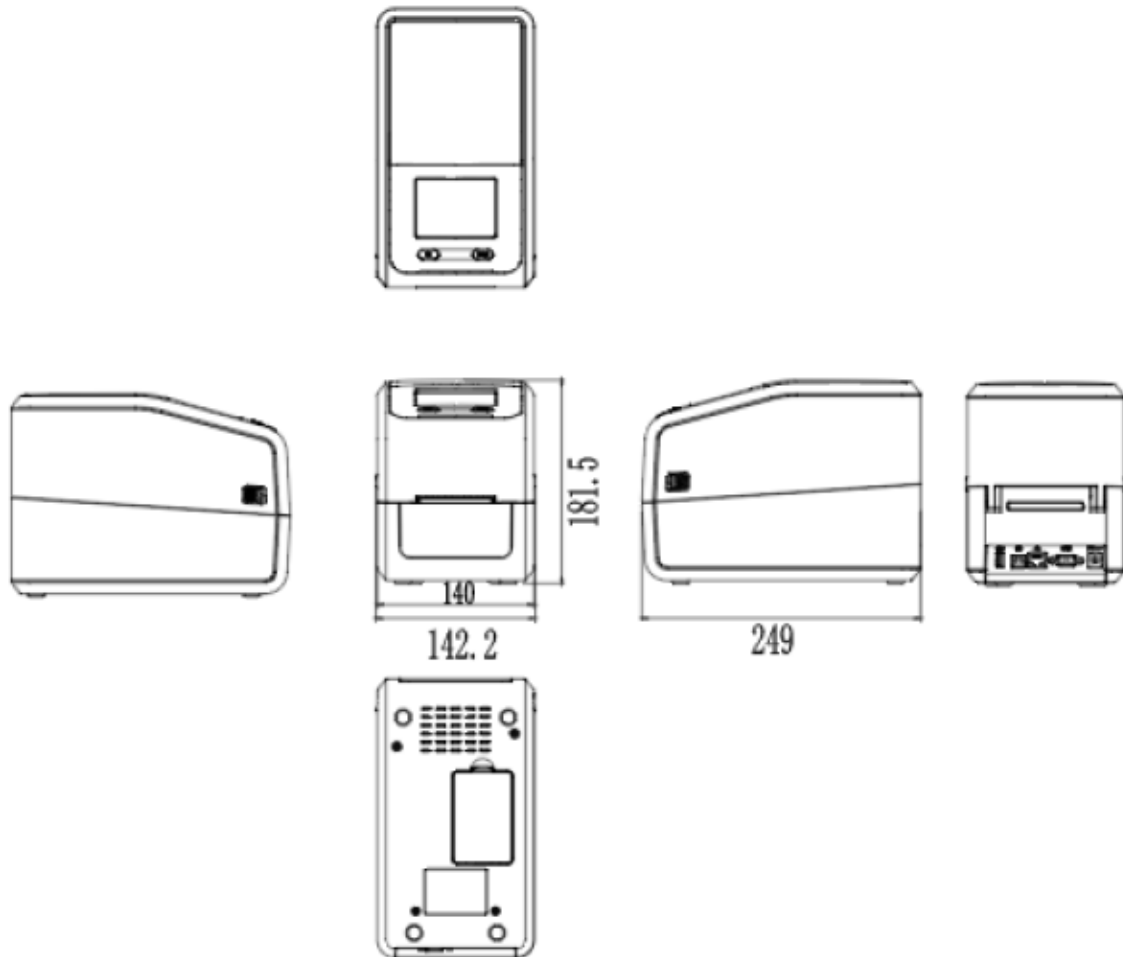

Unit: mm

## Chapter 2 Specifications

(2/1)

Item		Parameter	
Type		iE2X	iE2P
<b>Printing</b>	Printing Method	Direct thermal	
	Resolution	STD 203dpi, OPT 300dpi	
	Max.Printing Speed	8 ips203dpi/6 ips300dpi	
	Max.Printing Width	54 mm(203dpi),56.9 mm(300dpi)	
	Max.Pringting Length	2,286mm(203dpi),1,524mm(300dpi)	
<b>Memory</b>	RAM	32MB	
	Flash	16MB	
<b>Programming Language</b>		ZPL-II,EPL-II,DPL	
<b>Sensor</b>	Gap Detection	2 intermediate transmissive detection	
	Black Mark Detection	1 reflective detection, full move	
	Other Detection	Paper out detect, cover open detection, thermal head over heating detect	
<b>Media</b>	Types	Continuous paper, gap label, black mark label, punched hole label	
	Width	20-60mm, include the liner	
	Thickness	0.002"(60um)-0.01"(250um)	
	Label Roll Diameter	5"(127mm) Max	
<b>Software</b>	Label Design Software	iDPRT Bartender Ultralite	
	Driver	Windows 7,8,10, Server 2008,2012 Linux and MAC OS	
<b>Fonts</b>	Resident Fonts	Alphanumeric, Simplified Chinese, Traditional Chinese, 29 international character sets	
	User defined Fonts	Support	

Item		Parameter	
<b>Barcodes</b>	1D	Code 39, Code 93, EAN 8/13 (add on 2 & 5), UPC A/E (add on 2 & 5), I 2 of 5, Codabar, Code 128 (subset A, B, C), UCC/EAN 128, MSI, Plessey, Telepen, GS1 DataBar, Standard 2 of 5, Industrial 2 of 5, Code 11, Code 49, POSTNET, ITF14, HIBC, FIM, German Post Code, Planet 11&13, Japanese Postnet, Interleaved 2 of 5, Logmars, Code 11	
	2D	Code 49, Codablock, PDF417, Data matrix code, Maxicode, QR code, Micro PDF417, Aztec code	
<b>Interfaces</b>	Standard	USB Type-B	USB Type-B, USB HOST, RS232, Ethernet
	Optional	Wi-Fi, Bluetooth	
<b>Control Panel</b>		Power switch button, FEED button	
<b>LCD Display</b>		None	3.5" TFT LCD with Navigation Button
<b>RTC Function</b>		None	Standard
<b>Power Supply</b>		AC 100V-240V/DC, 24V/2.5A	
<b>Environment</b>	Operation	5 to 50°C @ humidity 25% to 85% non-condensing	
	Storage	-40 to 60°C @ humidity 10% to 90% non-condensing	
<b>Physical</b>	Dimension	249*142.2*181.5mm (L*H*W)	
<b>Characteristic</b>	Weight	About 1.5 kg	About 1.6 kg
<b>Options &amp; Accessory</b>		Cutter Module, External Label Roll Holder	
<b>Agency Approval</b>		CE EMC (EN 55022 Class B), FCC EMC (Class A), CCC, RoHS	

## Chapter 3 Installation & Usage

### 3.1 Media Loading

#### 3.1.1 Loading the Roll

1. Pull and lift the cover. (e.g. iE2P)

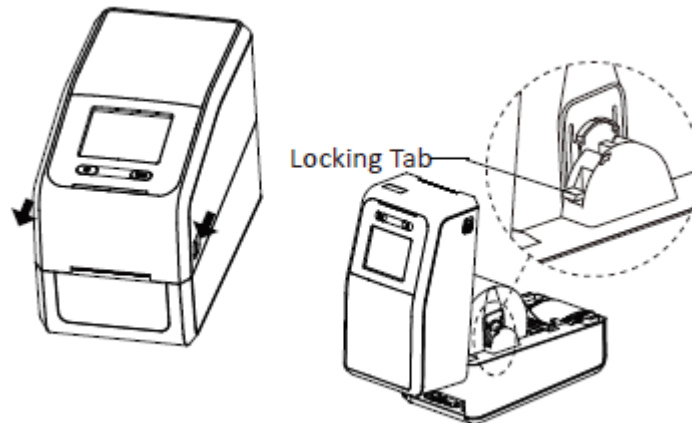

**Note:** After lifting the top cover, the locking tab will hold the top cover to prevent the top from falling and hurting hands.

2. Put the paper roll into the axis according to the inner diameter of the paper roll.

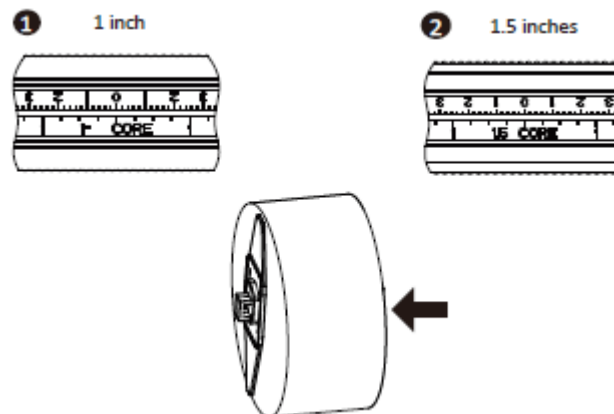

**Note:** When using 1-inch paper roll, the font of "1 CORE" should be upward; when using 1.5-inch paper roll, the axis should be turned 180 degrees and the font of "1.5 CORE" should be upward.

3. Place the roll into the printer.

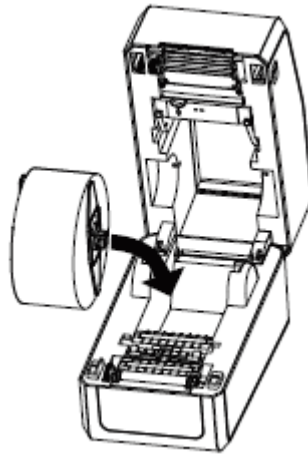

4. Pass the label through the label guides, then adjust guides to adapt to the label width.

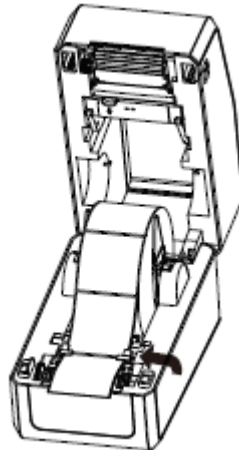

5. Press the cover lock and close the cover slightly.

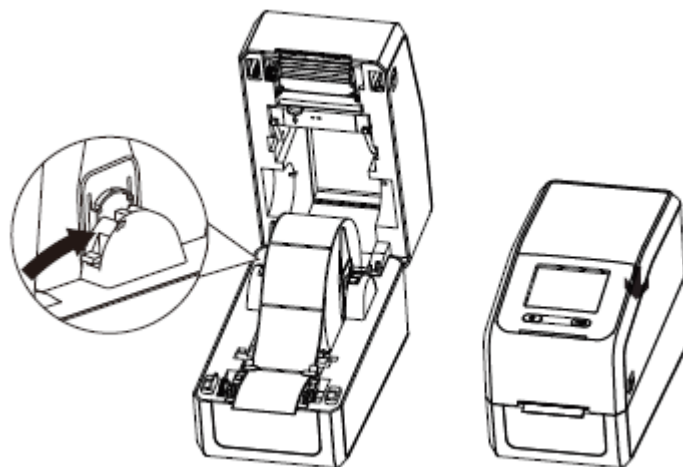



### 3.1.2 Loading the Ribbon

1. Insert the right part of supply spindle, then the left part.

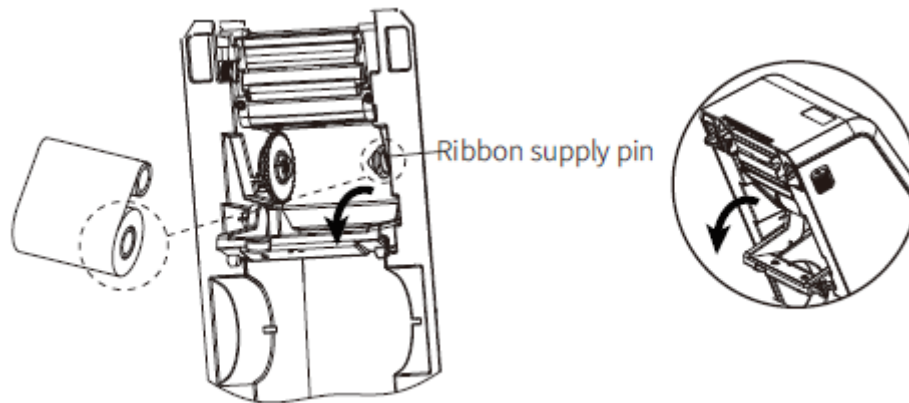

**Note:** Please follow the figure above to ensure that the ribbon is loaded in the right direction. When the ribbon is installed, the smooth face should be toward the print head and the fog face should be toward the platen.

2. Loosen the upper sensor bracket and put it back after the ribbon supply part is installed.

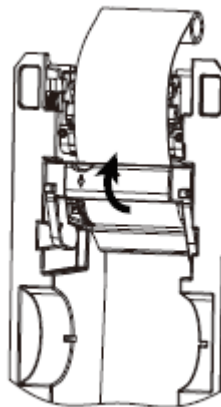

3. Hold the handle of the lower bracket and push the top cover upward.

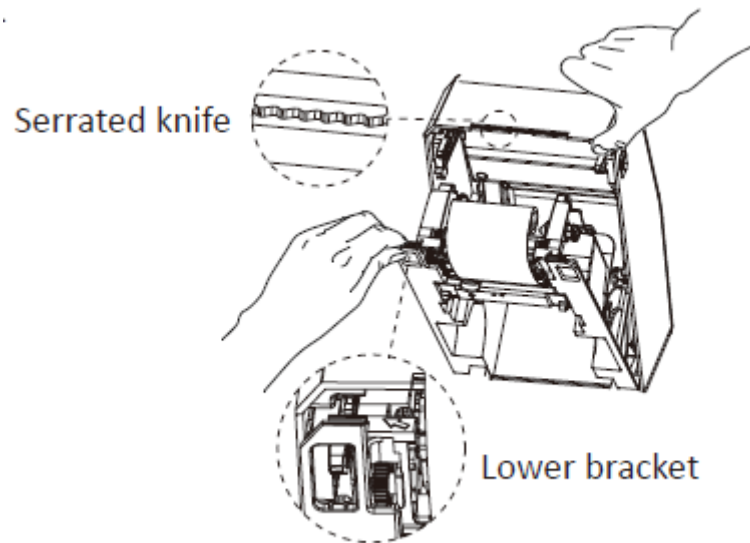

4. Ring the ribbon up. Then embed the right side of the ribbon rewind shaft in the ribbon rewind pin, and embed the left side of the ribbon rewind shaft in the ribbon rewind wheel.

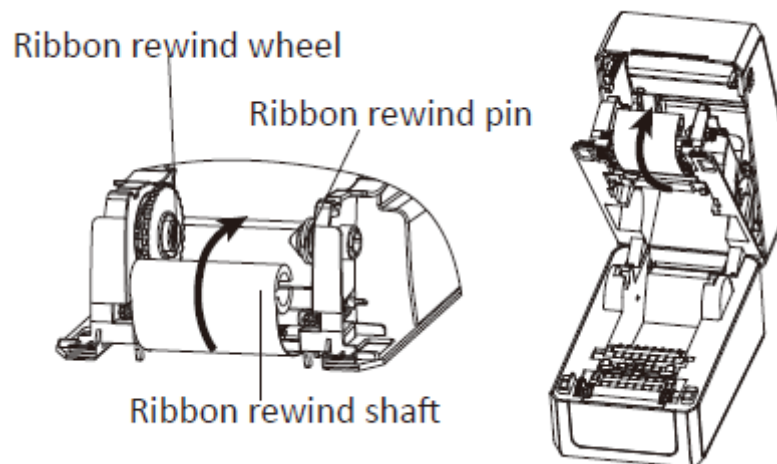

5. Rotate the ribbon rewind wheel until ribbon is pulled rightly.

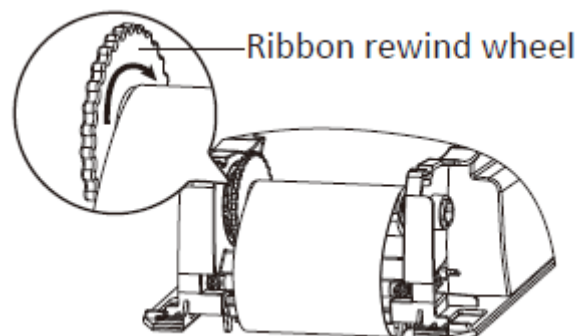

6. Press the cover lock and close the cover slightly.

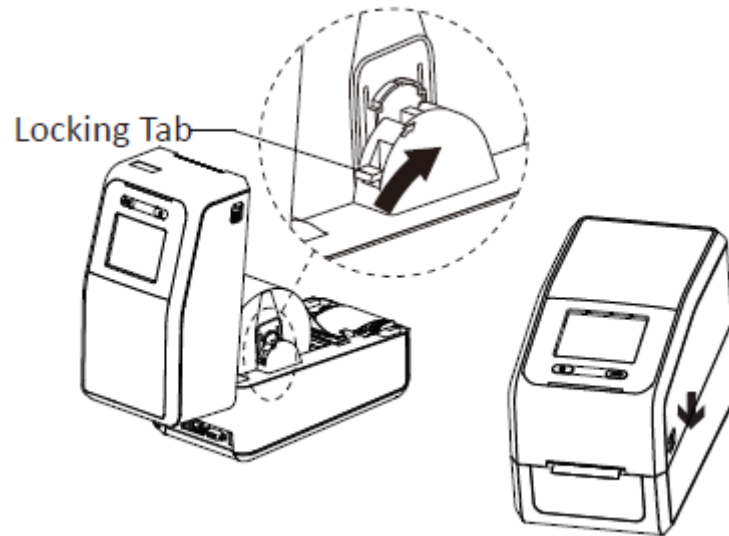

### 3.2 Power Connection

1. Connect the AC adapter to power receptacle.
2. Connect the power cord to AC adapter.
3. Connect the other end of power cord to the outlet.

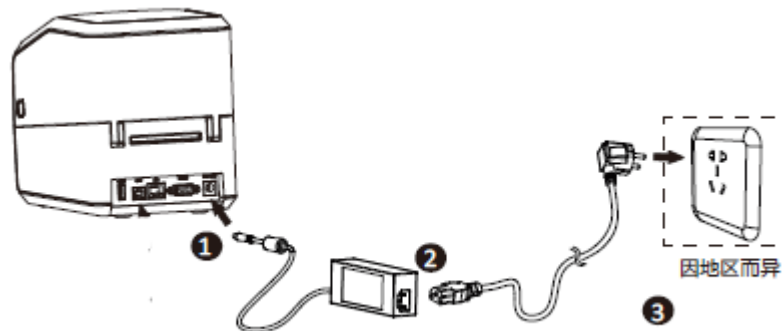

#### Caution:

- Use the original power adapter only. Avoid the damage caused by charging improperly.
- Please unplug the printer power cord if it is not in use for a long time.

## 3.3 Peripherals Connection

### 3.3.1 Interface Cable Connection

1.The standard for the printer's interface cable shows as follows:

- USB A-Type cable
- USB B-Type cable
- RS-232C cable
- RJ45 cable

2.Based on your own need, follow the instructions to connect the cable.

- 1) Make sure the printer's power is off.
- 2) Please plug in the cables.
  - Insert the USB A-Type cable into the USB (type A) interface.
  - Insert the USB B-Type cable into the USB (type B) interface.
  - Insert the RS-232C cable into the serial interface.
  - Insert the RJ45 cable into the ethernet interface.

### 3.3.2 Bluetooth Connection

PDA with Bluetooth interface, laptop and other information terminals can drive the printer.

Instructions show as follows:

1. Power on the printer.
2. Primary device searches for outer Bluetooth devices.
3. If there are other Bluetooth devices, select printer's name.
4. Finish pairing.

If you need more detailed information of pairing methods, please refer to the instructions of Bluetooth device.

After pairing, primary devices with virtual Bluetooth interface (smart phone, tablet, pocket PC, palm, notebook) can drive the printer iE2P or iE2X to print labels through virtual Bluetooth interface.



**Note: The original code is 0000.**

### 3.4 Detection

When printing paper, the moveable label sensor is used to detect paper. The label sensor moves differently when using various kinds of paper. If user moves the sensor improperly, paper may not be detected, therefore the printer could not print paper. The following instructions tell users how to use label sensor correctly. Please read it carefully.

#### 3.4.1 Continuous Paper

When printing continuous paper (Figure 1), the sensor shall be aimed at the triangle below (Figure 2), which is the original position.

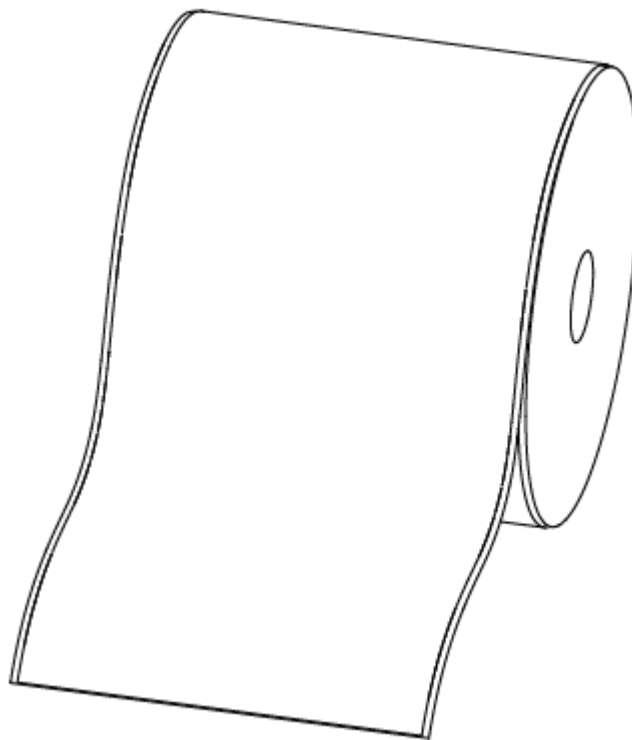

Figure 1 (Continuous Paper)

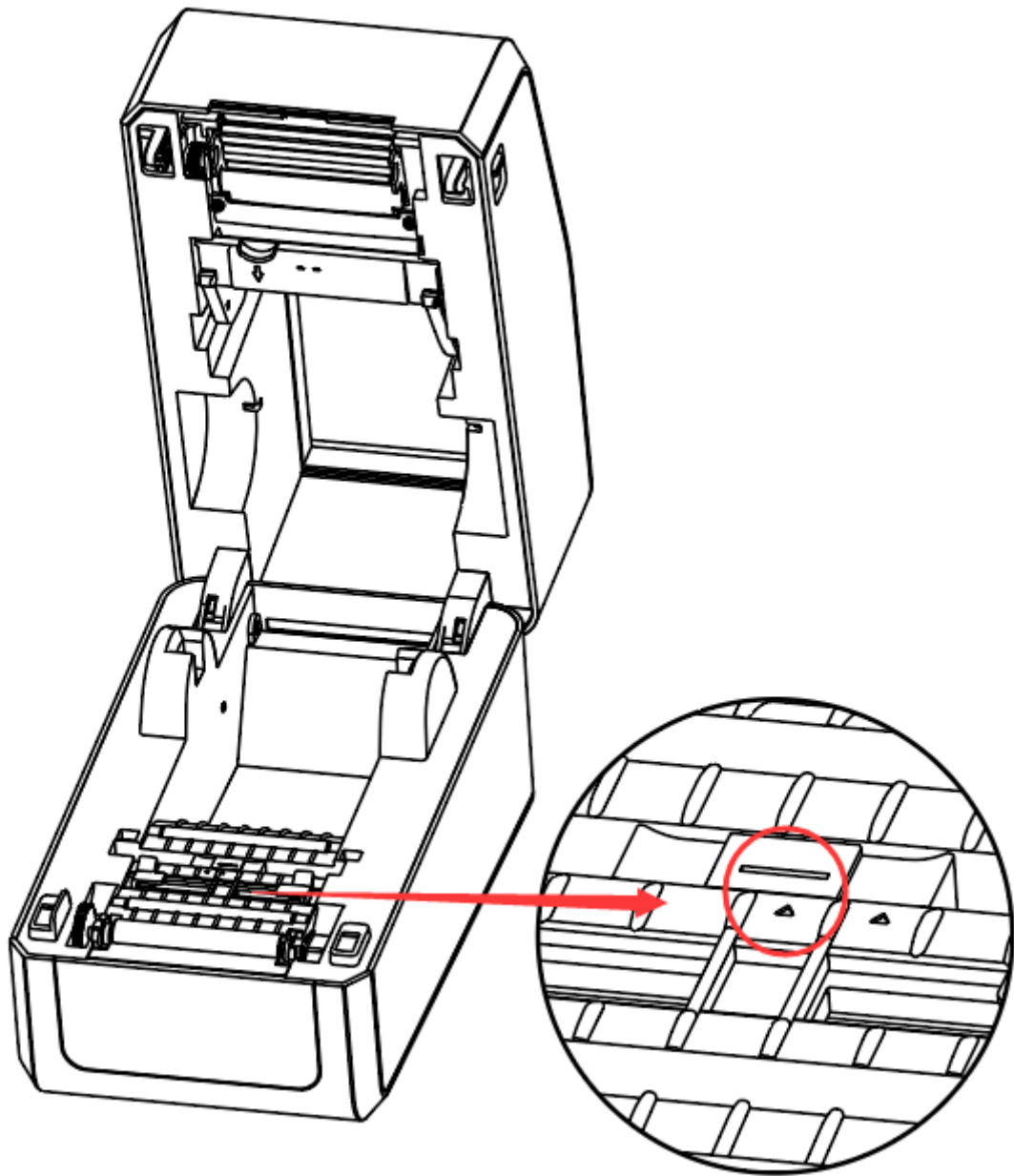

Figure 2

### 3.4.2 Labels

When printing labels (Figure 3) or double-row labels (Figure 4), the sensor shall be aimed at the triangle below (Figure 5), which is the original position.

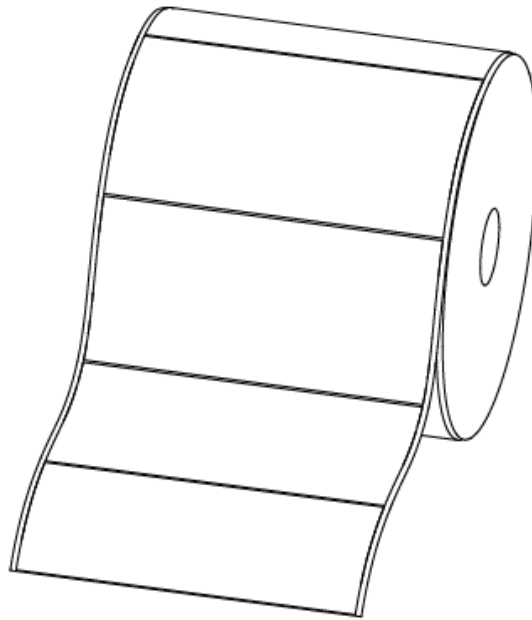

Figure 3 (Labels)

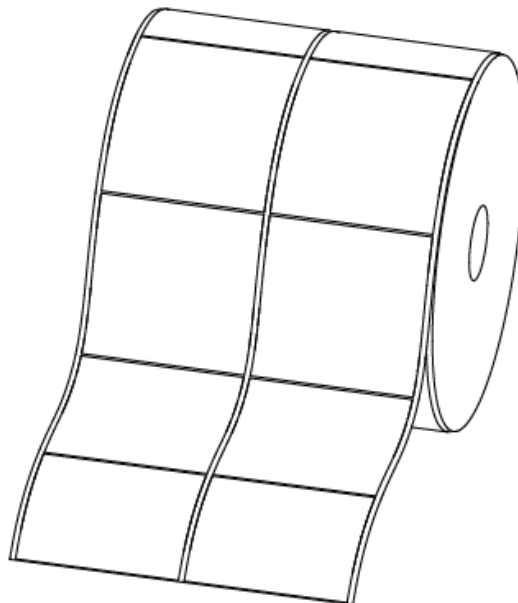

Figure 4 (Double-row Labels)

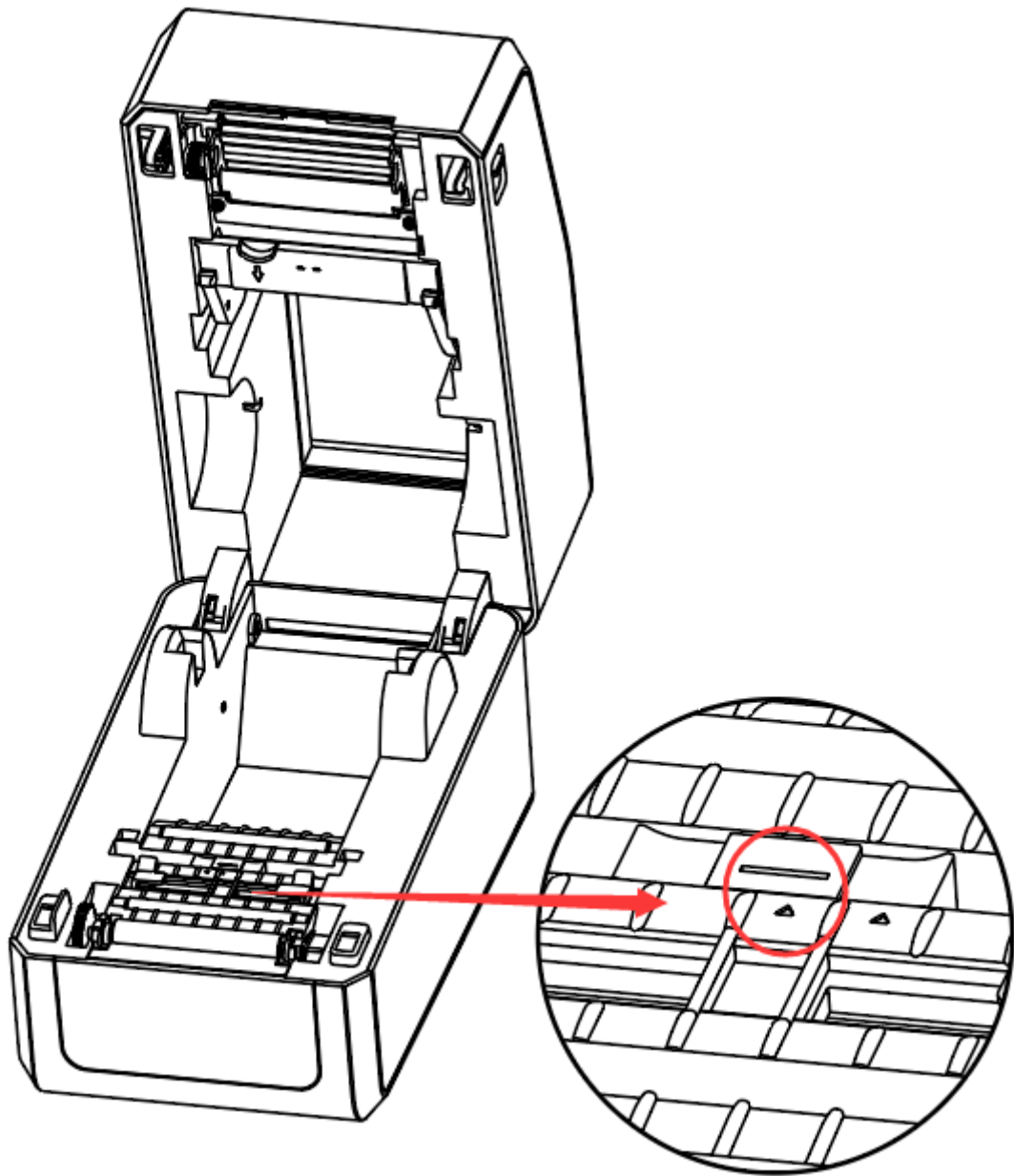

Figure 5



### 3.4.3 Punched Hole Label

When printing punched hole labels, move the sensor until it's aimed at the triangle below (Figure 6).

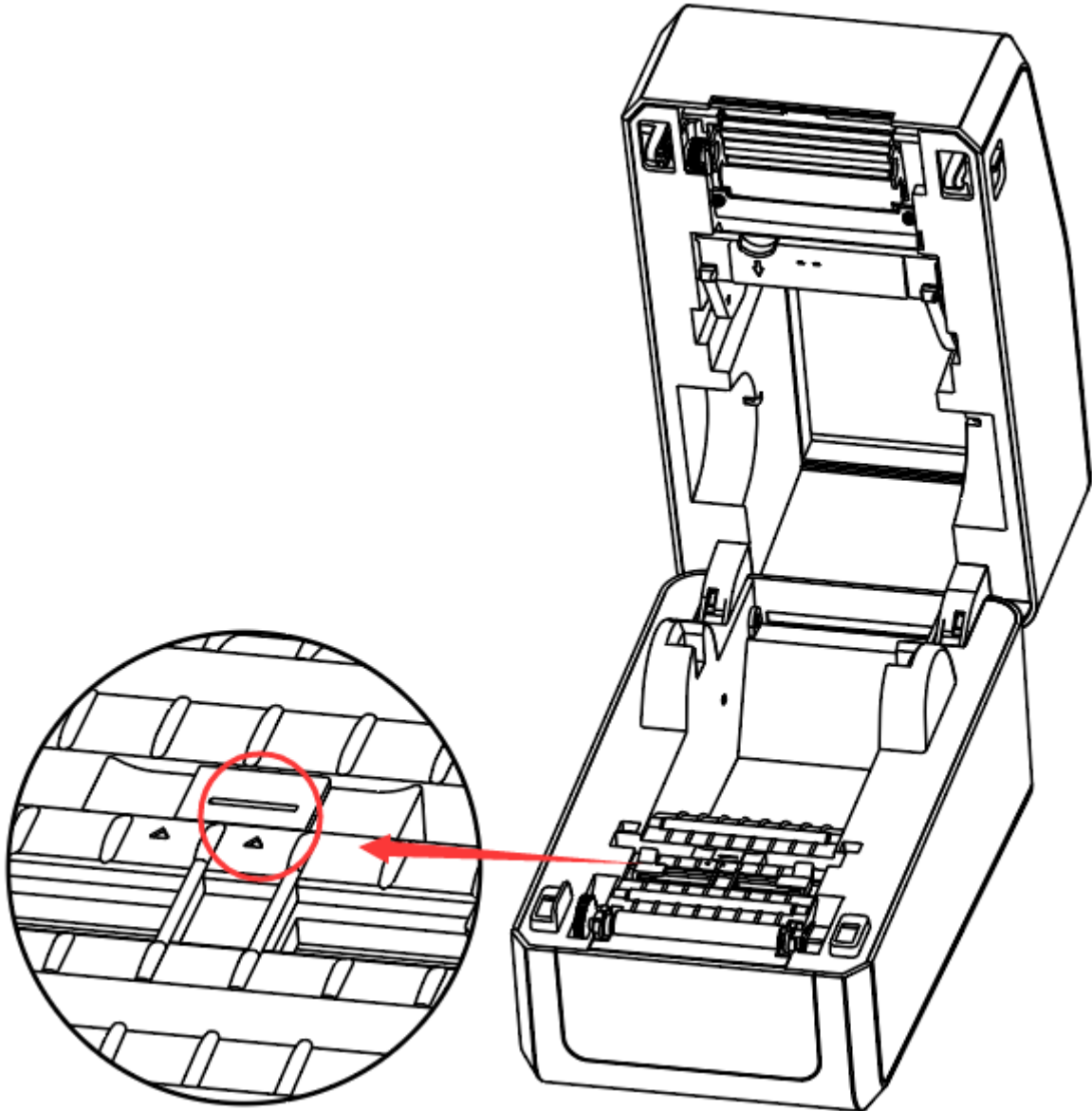

Figure 6

### 3.4.4 Blackmark Paper

When printing blackmark paper (Figure 7), the sensor shall be aimed at the position of black mark (Figure 8).

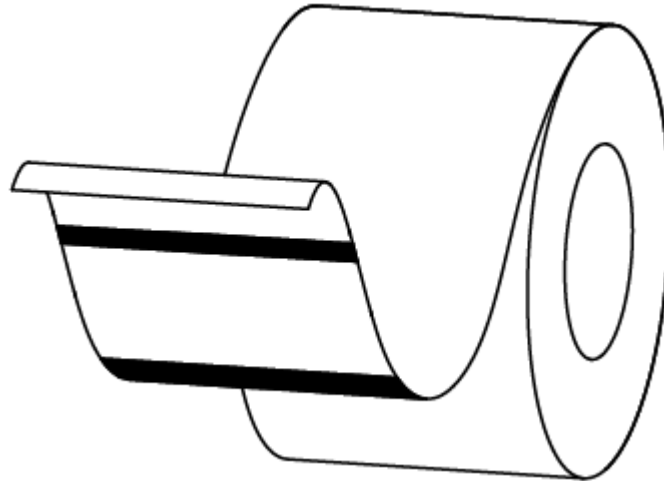

Figure 7 (Blackmark Paper)

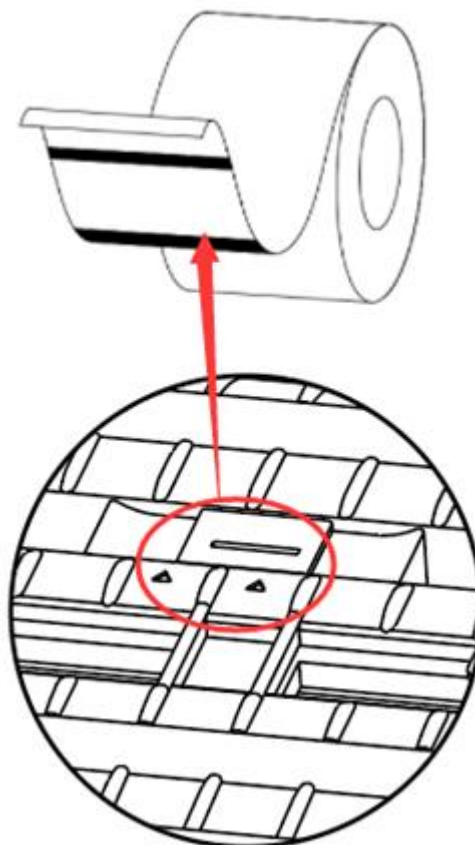

Figure 8 (aimed at blackmark's position)

## 3.5 Operation Panel

### 3.5.1 Panel Introduction

The panel indicates the printer's operating status and allows the user to control basic printer operation.

#### 1.Power Button



Much more detailed information is provided in "3.7.1 Power On/ Power Off".

#### 2.Feed Button



#### 3.Directionals Pad (only for printer iE2P)

---

2020/01/01←  
13:20:01



- 1) When the printer power on, the idle display will appear.
- 2) It contains printer's name, version number of the firmware, time and menu.

2020/01/01 ←  
13:20:01



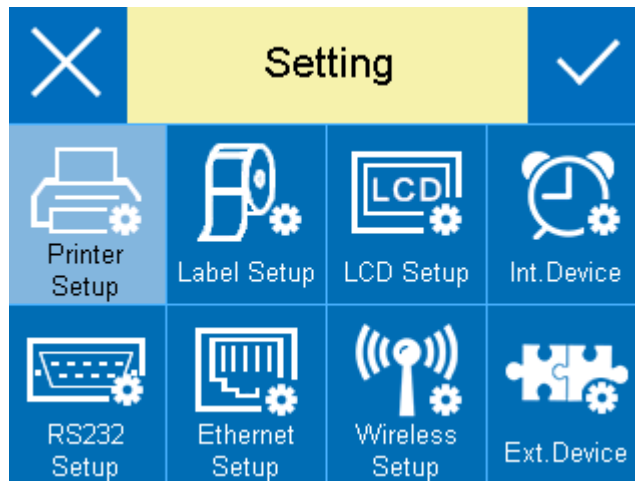

Home Menu Display

3) User can operate the printer by display in home menu.



Sub-menu Display

4) User can switch this function by  or .

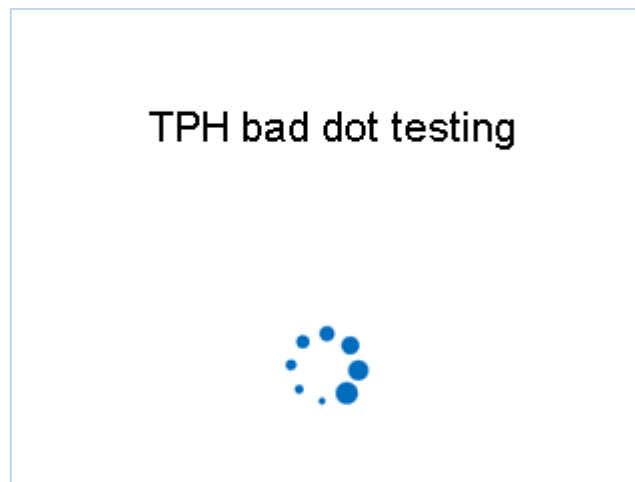

Operating Display

- 5) When operating display appears, it means that printer is carrying the command that user has sent. After finishing the task, printer will return to the sub-menu display.

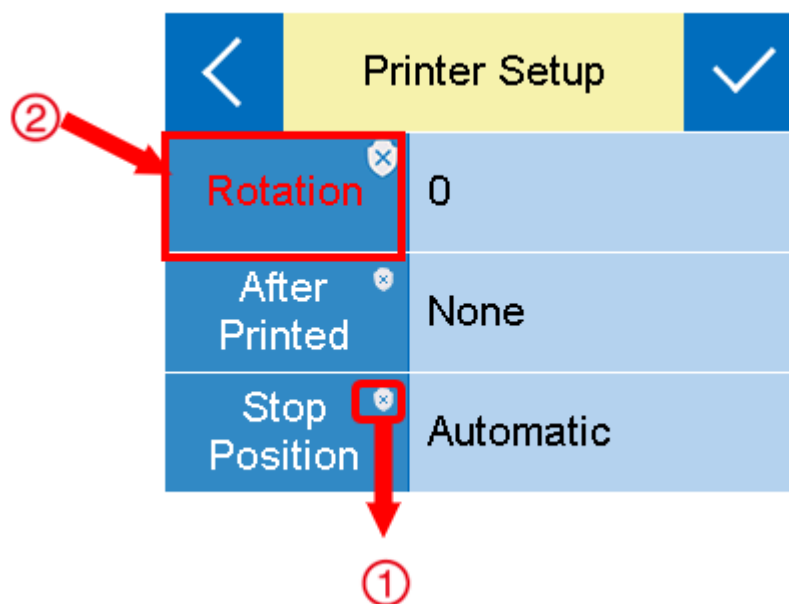

- ① The item with red frame: When the item is white, the relevant values could be changed both by display operation and software instructions. When the item turns yellow, the relevant values have been protected and can only be changed by display operation.

- ② User can change the item into another status by clicking the corresponding value.

### 3.5.2 Display Operation



Note:

- The display operation of printer iE2P is controlled by directional pad.
- The highlighted item represents that user has chosen the item needed.

In the following instructions, the example will be taken to show user how to operate the printer.

Changing the speed of the printer:

- 1) Press the power button to open the printer’s power.
- 2) Enter the home menu.

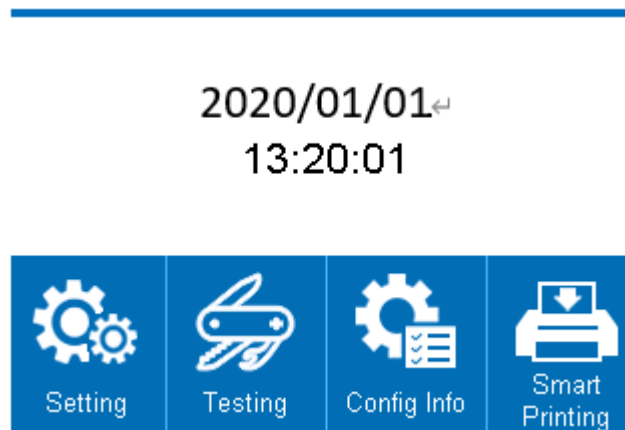

- 3) Enter the setting menu, then choose the “Printer Setup” item.

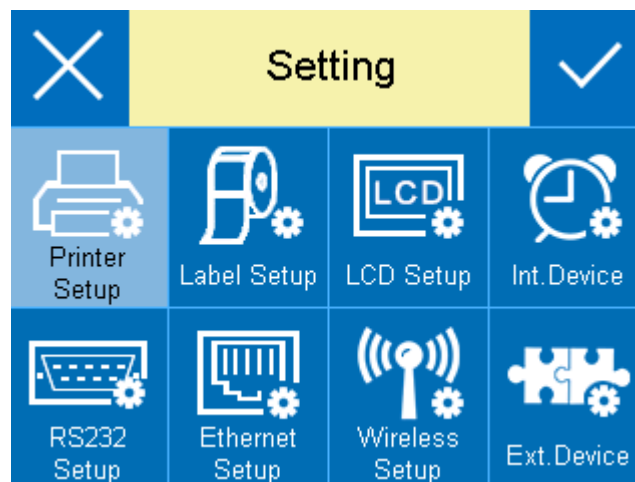

4) Users can click on settings such as print mode, print speed and print concentration as needed;



Click to enter other settings options

Printer Setup	
Print Method	<input checked="" type="radio"/> DT <input type="radio"/> TT
Print Speed	4 ips <span style="float: right; background-color: #0070c0; color: white; padding: 2px 5px;">+</span>
Print Darkness	10 <span style="float: right; background-color: #0070c0; color: white; padding: 2px 5px;">+</span>



5) Click to save the settings above.

Printer Setup	
Print Method	<input checked="" type="radio"/> DT <input type="radio"/> TT
Print Speed	6 ips <span style="float: right; background-color: #0070c0; color: white; padding: 2px 5px;">+</span>
Print Darkness	10 <span style="float: right; background-color: #0070c0; color: white; padding: 2px 5px;">+</span>



**Note:**

- For more information about the display menu, please refer to the appendix.
- The above illustration is for reference only, the display interface is based on real operation.
- Set individual items have password locking function, once the password lock function must be entered in the correct password to enter the system settings. For the locked setup item, the printer automatically excludes the corresponding setup instructions from the print task.

### 3.5.3 Indicator Instructions

Color	Indicating Status
None	The printer is off
Green	Printing
Blue	Standby
Green Slow flash	Manual operation/ (FEED button/ paper fetching detection) print
Green Quick flash	Receiving data
Orange	Ribbon out
Orange Slow flash	Pause print
Orange Quick flash	Program downloading and updating
Red	Cover open/paper out
Red Slow flash	Label format does not match
Red Quick flash	Paper jam/label's separation



Note:

**Quick flash → 0.2 second / every cycle**

**Slow flash → 1 second / every cycle**

### 3.6 Buzzer

1. Silence: not set / normal
2. Beep 0.2 seconds: button response / touch response
3. Beep 1.5 seconds and stop 2 seconds: during printing, run out of paper / label off / paper jam



## 3.7 Basic Function

### 3.7.1 Power On/ Power Off

- When the printer is off, press the power button once, and the printer will be on.
- When the printer is on, hold press the power button, and the printer will be off.

### 3.7.2 FEED Button

- In ready state:
  - a) Short press (0.1-0.5s) to print a blank label (gap mark/ black mark label); continuous paper is fixed for 30mm;
  - b) Press and hold for approx. 2s, release the feed button after the light goes out for 1 time, the printer will print the self-test page;
  - c) Press and hold for approx. 3s, release the feed button after the light goes out for 2 times, the printer will enter the automatic label learning;
  - d) Press and hold for approx. 5s, release the feed button after the light goes out for 4 times, the printer will be automatically restoring the factory settings and restarts.
- Printer is printing: Short press to pause printing.
- Printer pause: Press the feed button to continue printing.
- Dumping mode: Short press the feed button to back to normal print mode.
- Green light slow flash: Short press the feed button to print one sheet.
- Red light slow flash: Short press to print a blank label (seam mark/ black mark label), continuous paper is fixed for 30mm.
- In ready state: Short press the feed button, printer will print one sheet.

**Note:**

Short press: 0.3 seconds to 1 second;

Press and hold: More than 3 seconds.

---

### 3.7.3 Quick Calibration

**Users must carry out the calibration under the conditions below:**

- The first time to use the printer since installation;
- The first time to use the printer since sensor cleaning;
- Reuse the printer when it has not been used for a long time;
- Change a new type of media;
- Printer cannot recognize the mark;
- Huge change of the operating environment;

**Calibration method:**

- Carry out the calibration manually.

When printer is ready, press the FEED button for 3 seconds until the status indicator (Green) flashes twice. Then release the button, and printer will start to do the calibration. When printer does the calibration under Continuous Media Mode, the calibration is invalid.

- Carry out the calibration by printer utility tool.

Please refer to detailed information in “Chapter 6 Printer Utility Tool Instructions”.



**Note:**

**After the quick calibration, users could open the printer cover to pull back the learned paper in avoid of paper wasting.**

### **3.7.4 Print Self-test Page**

The self-test checks the printer's current settings, status and whether the printer has any problems or not.

#### **1.Printing Manually**

- 1) Make sure the roll is loaded properly.
- 2) Make sure the top cover of the printer is closed properly. Then turn on the printer.
- 3) When the printer is ready, press the feed button continuously. As soon as the indicator flashes (green) once, loosen the button. Then the printer starts to print the self-test page.

#### **2.Printing by Windows Driver Program**

- 1) Install the Windows Driver program.
- 2) Set the "Interface" as the type you use.
- 3) Use the Windows Driver Program to print out the "Self-test page".
- 4) Please refer to "Chapter 7 Seagull Windows Driver Instructions" for more detailed information.

#### **3.Printing by BarTender Ultralite Program**

- 1) Install the BarTender Ultralite program.
- 2) Edit a new label and print it.
- 3) Please refer to "Chapter 8 BarTender Ultralite Instructions" for more detailed information.

# Chapter 4 Interface

## 4.1 USB Interface

### 1.USB (Type A)

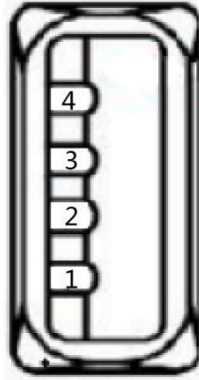

PIN	SIGNAL NAME
1	VBUS
2	D-
3	D+
4	GND

### 2.USB (Type B)

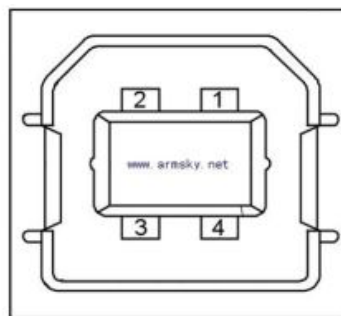

PIN	SIGNAL NAME
1	VBUS
2	D-
3	D+
4	GND

## 4.2 Other Optional Interfaces

### ■ Serial Port

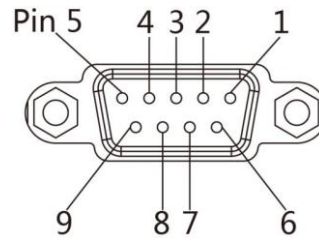

PIN	SIGNAL NAME	SIGNAL DIRECTION
1	+5VDC	OUTPUT
2	RXD	OUTPUT
3	TXD	INPUT
4	DTR	INPUT
5	GND	GROUNDING
6	DSR	OUTPUT
7	RTS	INPUT
8	CTS	OUTPUT
9	-	NO CONTACT

### ■ Ethernet Port

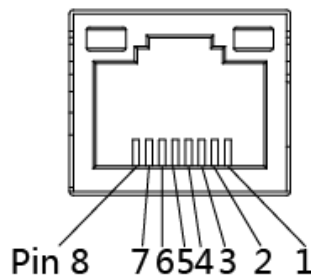

PIN	SIGNAL NAME
1	TX+
2	TX-
3	RX+
4	-
5	-
6	RX-
7	-
8	-

## Chapter 5 Maintenance & Adjustment

Adhesives and coatings of the media can transfer to the printer parts over time along the media path including the thermal print head and media sensor. This build-up can accumulate dust and debris. Failure to clean the print head, media path, and media sensor could result in inadvertent loss of labels, label jams and possible damage to the printer.

**Note:**

- 1) Make sure to turn off the printer prior to cleaning.
- 2) As the print head gets hot during printing, if intending to clean the print head, turn the printer off and wait approximately 2~3 minute before commencement.
- 3) When cleaning the print head, take care not to touch the heated portion of the print head. Print Head is susceptible to damage from static electricity, etc. So it is strongly recommended to wear hand gloves during cleaning progress.
- 4) Take care not to allow the print head become scratched and/or damaged in any way.

### 5.1 Cleaning Media Sensor

Debris or dirt on the paper sensor can cause a miss-read or unstable detection of the label gap. Clean with a cotton bud dampened with alcohol.

### 5.2 Cleaning Thermal Print Head

Thermal Paper stock on the print head, which degrades print quality. Clean the print head with methanol or isopropyl alcohol and a cotton bud. Do not touch the heating elements with your fingers.

- 1) Open the Printer Cover and then use the cleaning pen to clean the head in the direction from the center of the head to two sides.
- 2) After cleaning the head, do not use the printer until the alcohol used for cleaning evaporates completely (1~2 min) and the printer has completely dried.
- 3) Perform the cleaning process each time the paper roll is replaced to prevent print quality deterioration.

### 5.3 Cleaning Roller and/or Paper Path

- 1) Open the printer cover and then remove the paper.
- 2) Remove any dust or foreign substance using dry cloth or cotton swab.
- 3) Soak the cloth or cotton swab in alcohol for medical use and use it to remove adhesive foreign substances or other pollution materials.
- 4) After cleaning the parts, do not use the printer until the alcohol evaporates completely (1~2 min) and the printer has completely dried



**Note: Clean the parts when print's quality or label detection degrades.**

# Chapter 6 Printer Utility Tool Instructions

## 6.1 Installation Preparation

Download application program in CD. e.g. iDPRTUtility.exe

## 6.2 Usage



**Note:** The screen may vary slightly by different operating systems and models. Take printer iE2P as example. Please refer to printer iE2P when using printer iE2X.

1. Install "iDPRTUtility.exe", then open it.

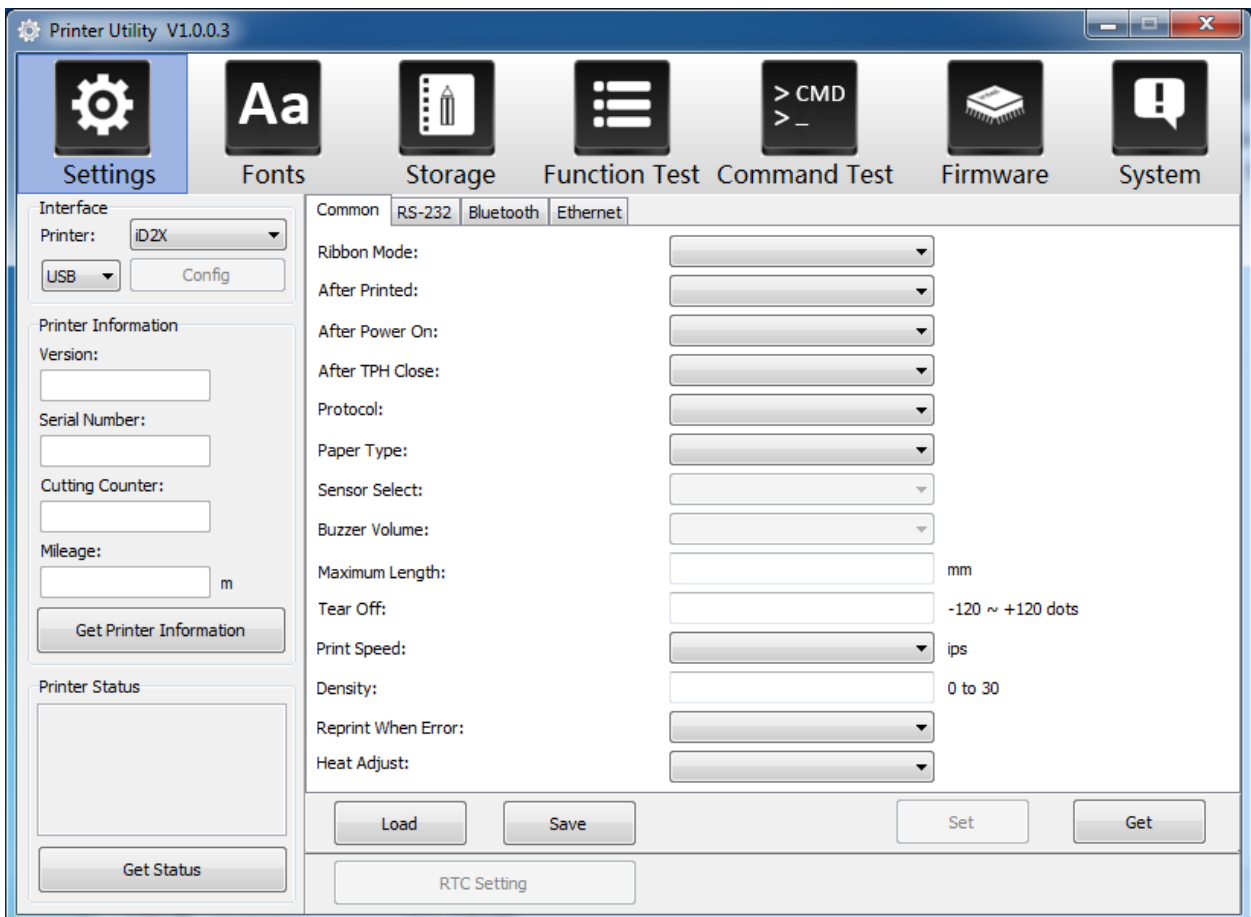



2. Click “Settings”, choose the printer model.

(1) Set up the interface needed. (range: USB, COM, ETH)

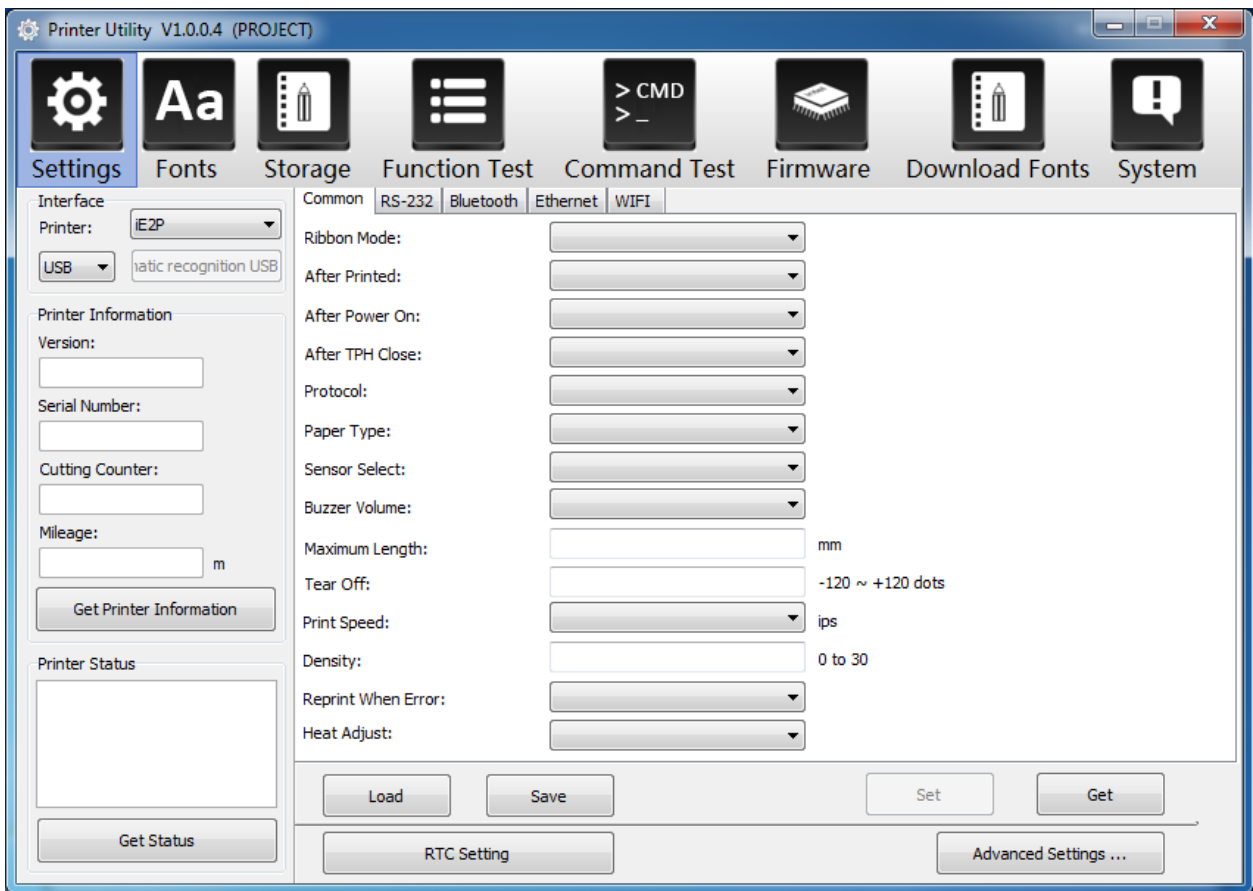

(2) Click “Get Printer Information”, and printer information will show in the above.

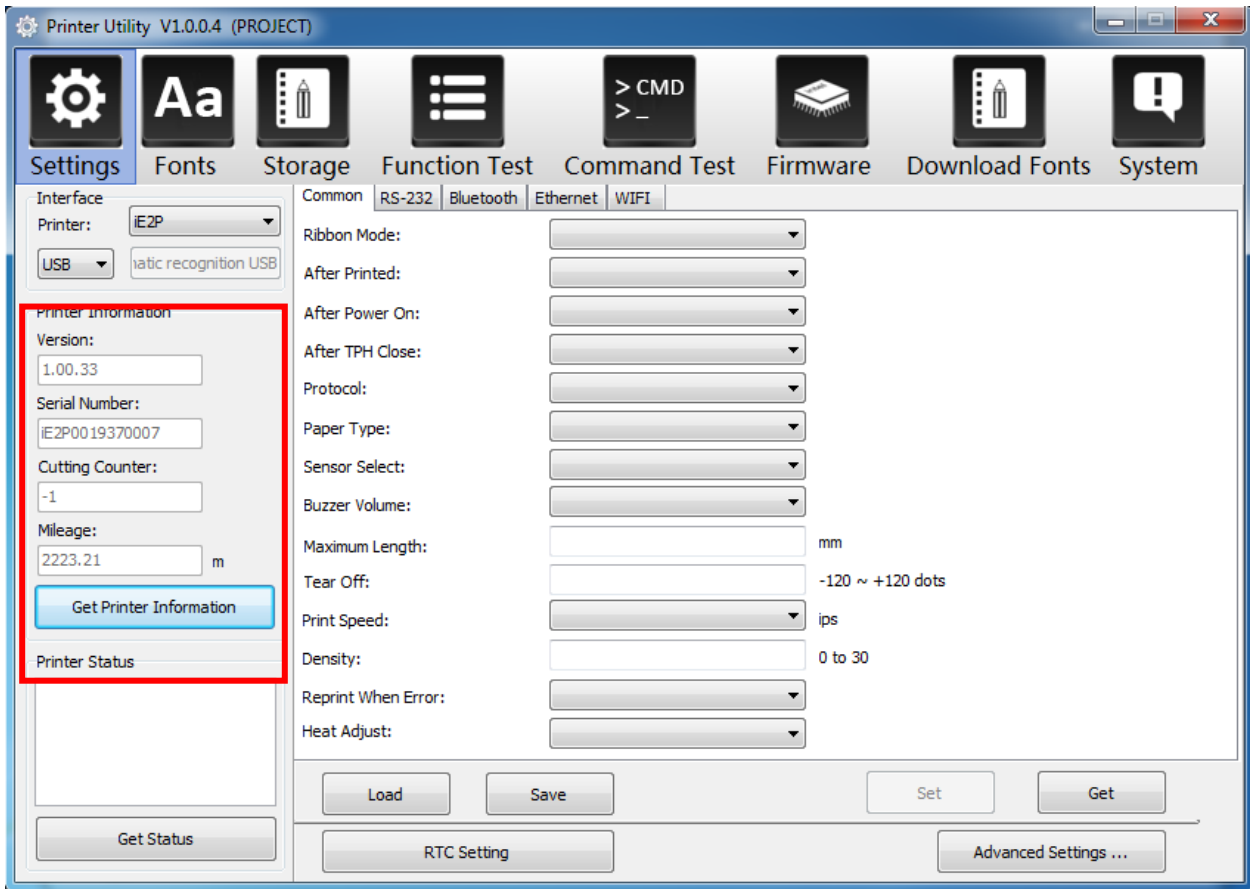

(3) Click “Get Status”, and printer status will show in the above.

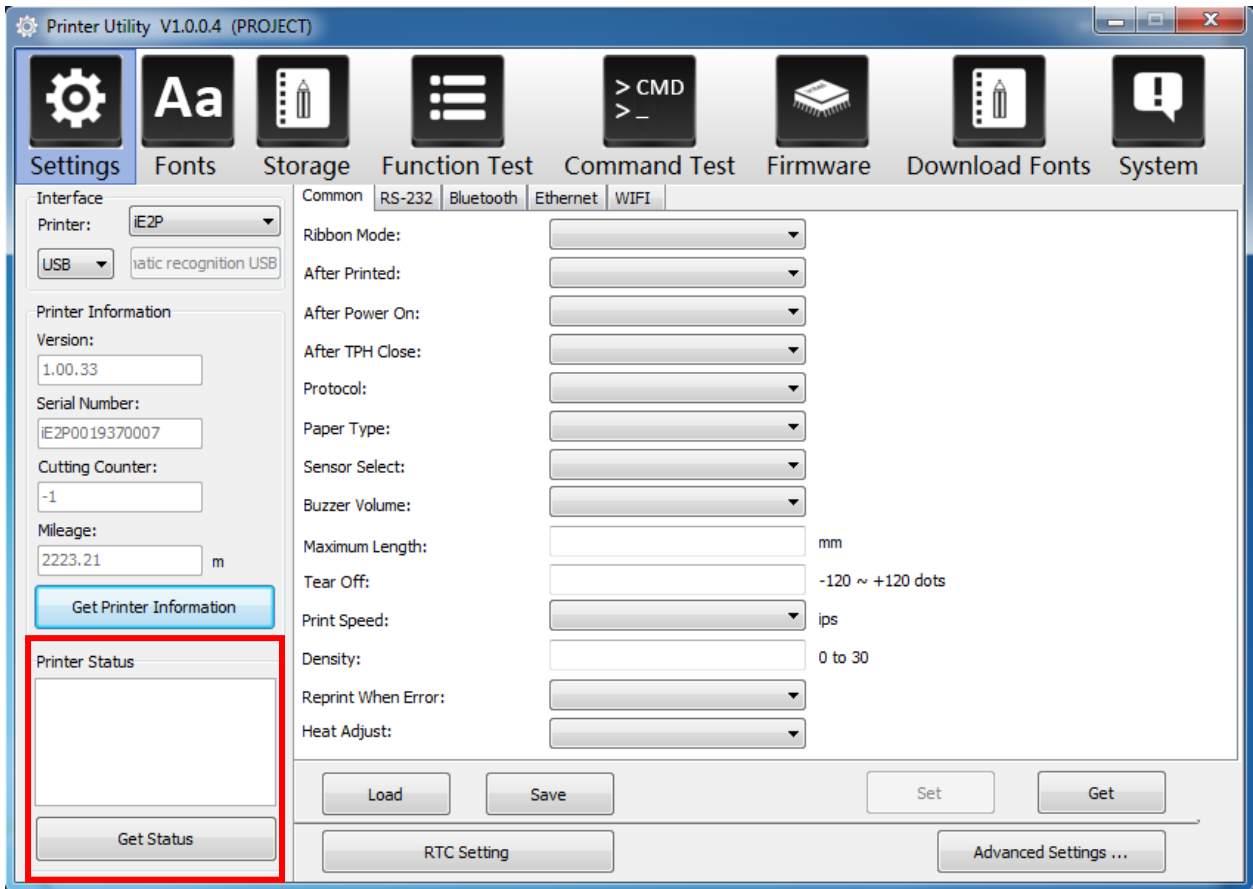

(4) Choose “Common” and click “Get”. In this menu, user can get the information of the protocol, media sensor, speed, density and so on.

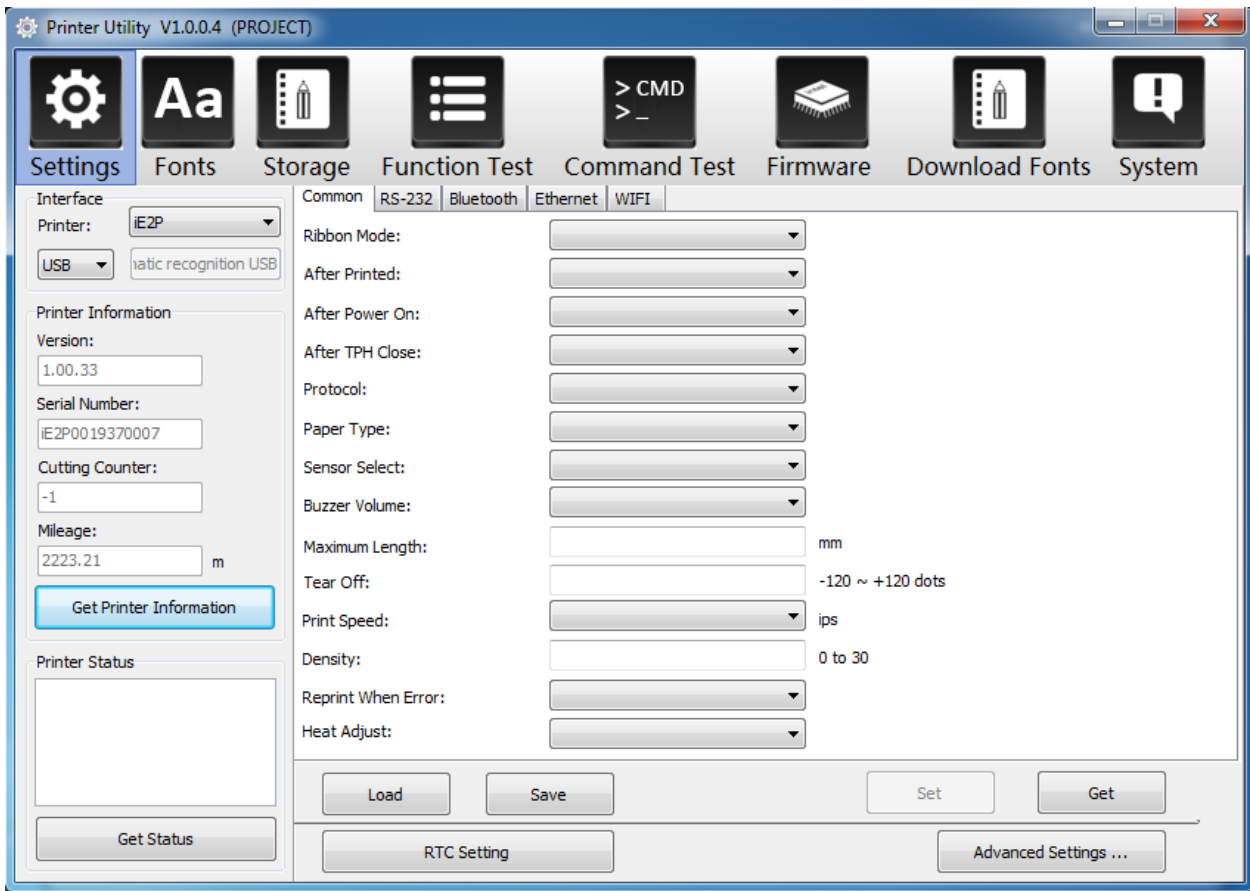

(5) Click “RS-232”, then set up the baud rate, data bits, parity and flow control.

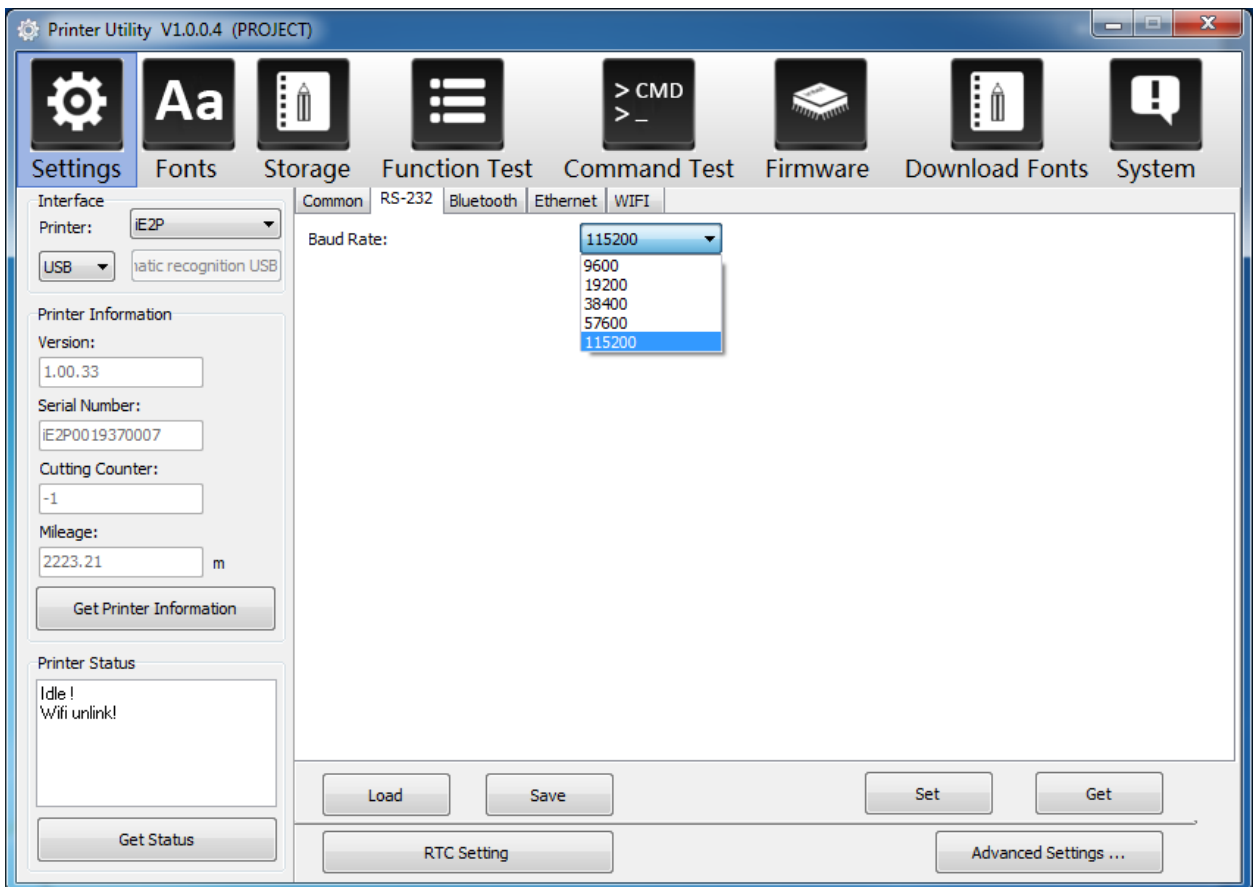

(6) Click “Bluetooth”, then set up the Bluetooth name and password. Click “Get” to gain the values of Mac address.

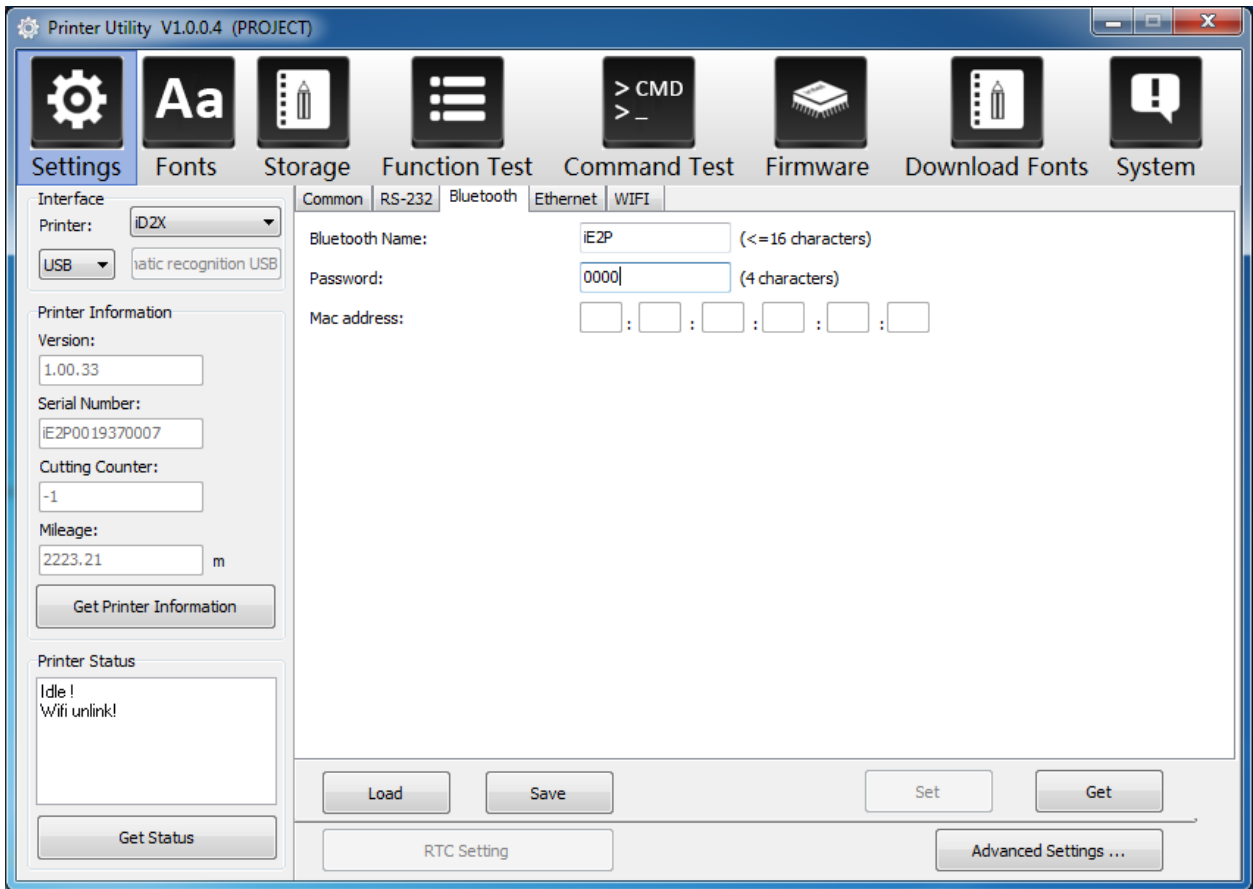

(7) Click “Ethernet”, then click “Get” to gain the relevant values.

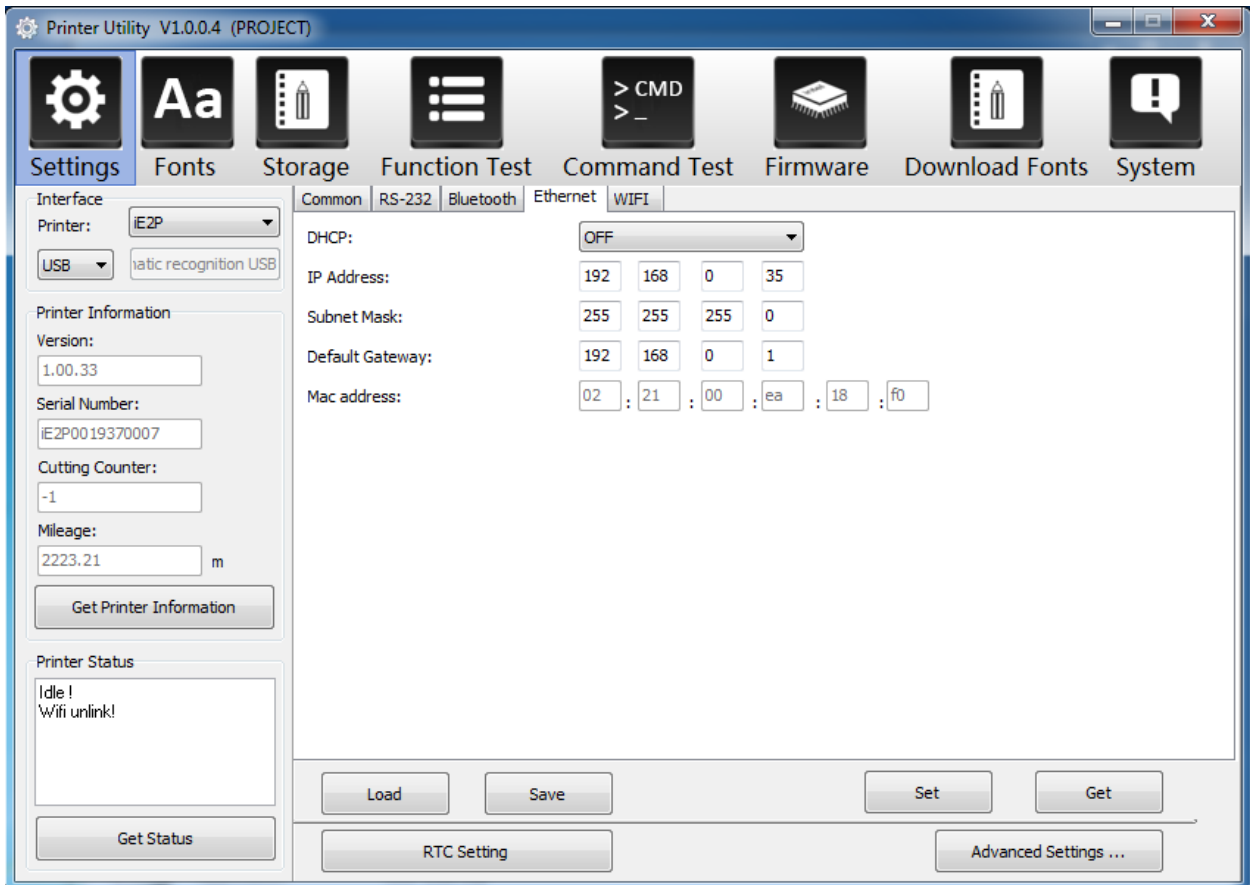

(8) Click “WIFI”, then set up the name, password and so on.

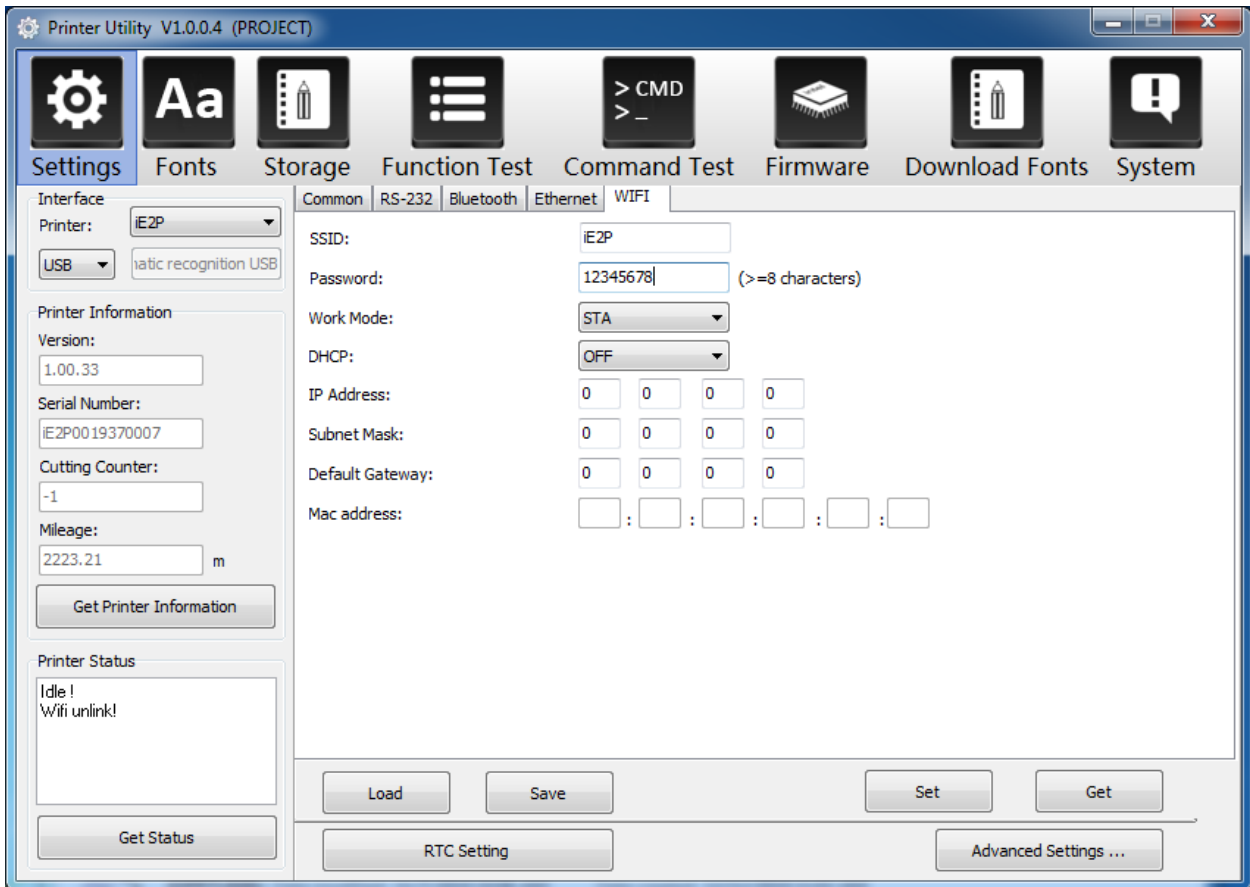



(9) Click “RTC Setting”. Click “Get System Date Time” to get the values, and click “Setup” to save them. Then click “Close”, and back to the main menu.

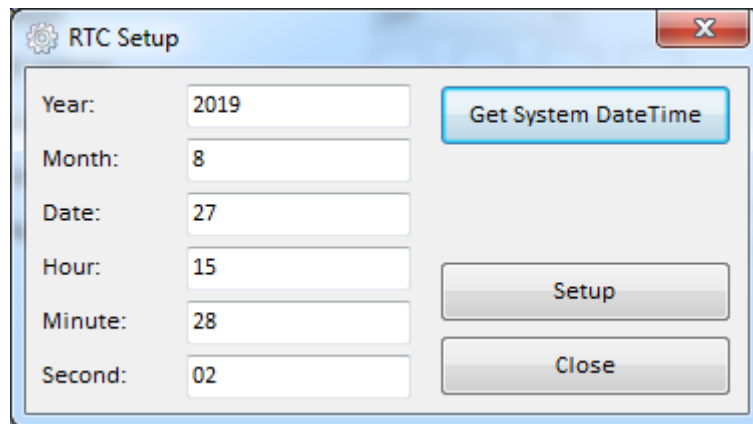

**Note:**

- ① Finishing all the settings, user can click “Set” to save the values changed.
- ② Click “Get”, and user will get the default values.

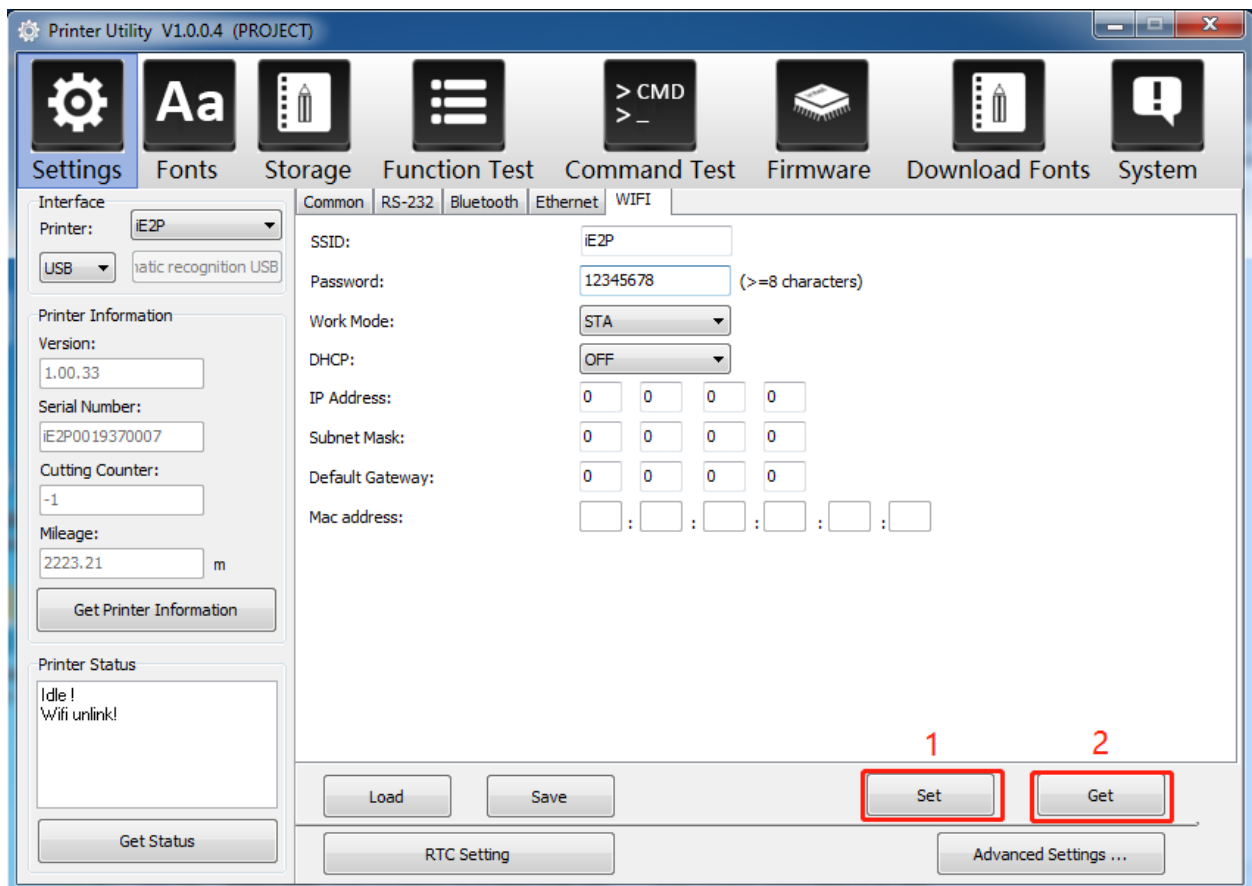

3. Click "Storage" to print image.

The screenshot shows a 'Download File' section with a 'File Type' dropdown set to 'Graphics' and a 'Magnification' dropdown set to '1.0'. Below these is a 'File Name' input field followed by a '...' button and a 'Download' button. Underneath, it displays 'Free space: 119,401,472B; Uses space 286,790,656B.' The main area is divided into three columns: 'Graphics', 'Label Form', and 'Auto Label Form'. Each column contains a large empty box and a set of buttons: 'List All...', 'Print Selected...', 'Delete Selected...', and 'Delete All...'.

(1) Click "File name" to select the image.

This is a close-up of the 'Download File' section. The 'File Name' input field is empty, and the '...' button to its right is highlighted with a red square. The 'Download' button is also visible to the right of the '...' button.

**Note:** The file name must be in English or number, and the filename length must be less than 32.

(2) Click "Download".

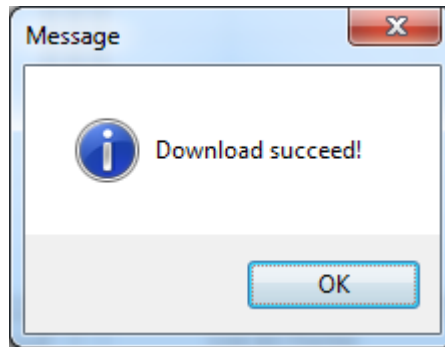

(3) Select the downloaded graphic, and then click "print selected graphic" to print the picture.

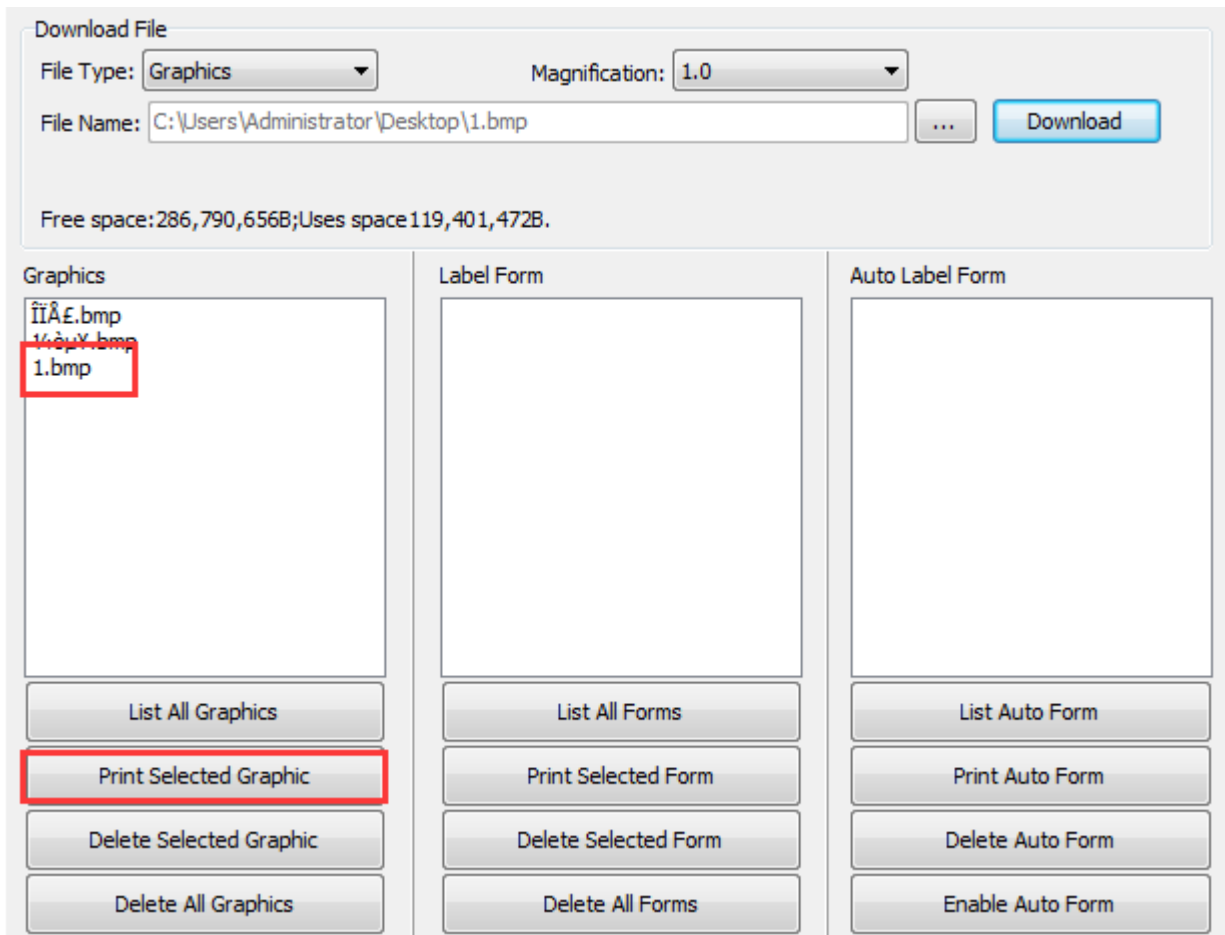

(4) You can set a magnification of the graphic as needed.

The screenshot shows the 'Download File' section of the software interface. At the top, there is a 'File Type' dropdown set to 'Graphics' and a 'Magnification' dropdown menu that is currently open, showing options 1.0, 1.5, 2.0, 2.5, and 3.0. The 'File Name' field contains 'C:\Users\Administrator\Desktop\1.bmp'. Below these fields, it displays 'Free space: 286,790,656B; Uses space 119,401,472B.' and a 'Download' button. Below the 'Download File' section, there are three columns: 'Graphics', 'Label Form', and 'Auto Label Form'. Each column contains a list of files or forms and a set of action buttons. The 'Graphics' column lists 'ÏÏÅ. bmp', '¼ôµ¥. bmp', and '1. bmp'. The 'Label Form' column is currently empty. The 'Auto Label Form' column is also empty. The buttons for each column are: 'List All Graphics', 'Print Selected Graphic', 'Delete Selected Graphic', and 'Delete All Graphics' for the Graphics column; 'List All Forms', 'Print Selected Form', 'Delete Selected Form', and 'Delete All Forms' for the Label Form column; and 'List Auto Form', 'Print Auto Form', 'Delete Auto Form', and 'Enable Auto Form' for the Auto Label Form column.

4. Click "Fonts". (Users can download the required fonts from the network)

(1) Click "Select Font" to select the vector font you want.

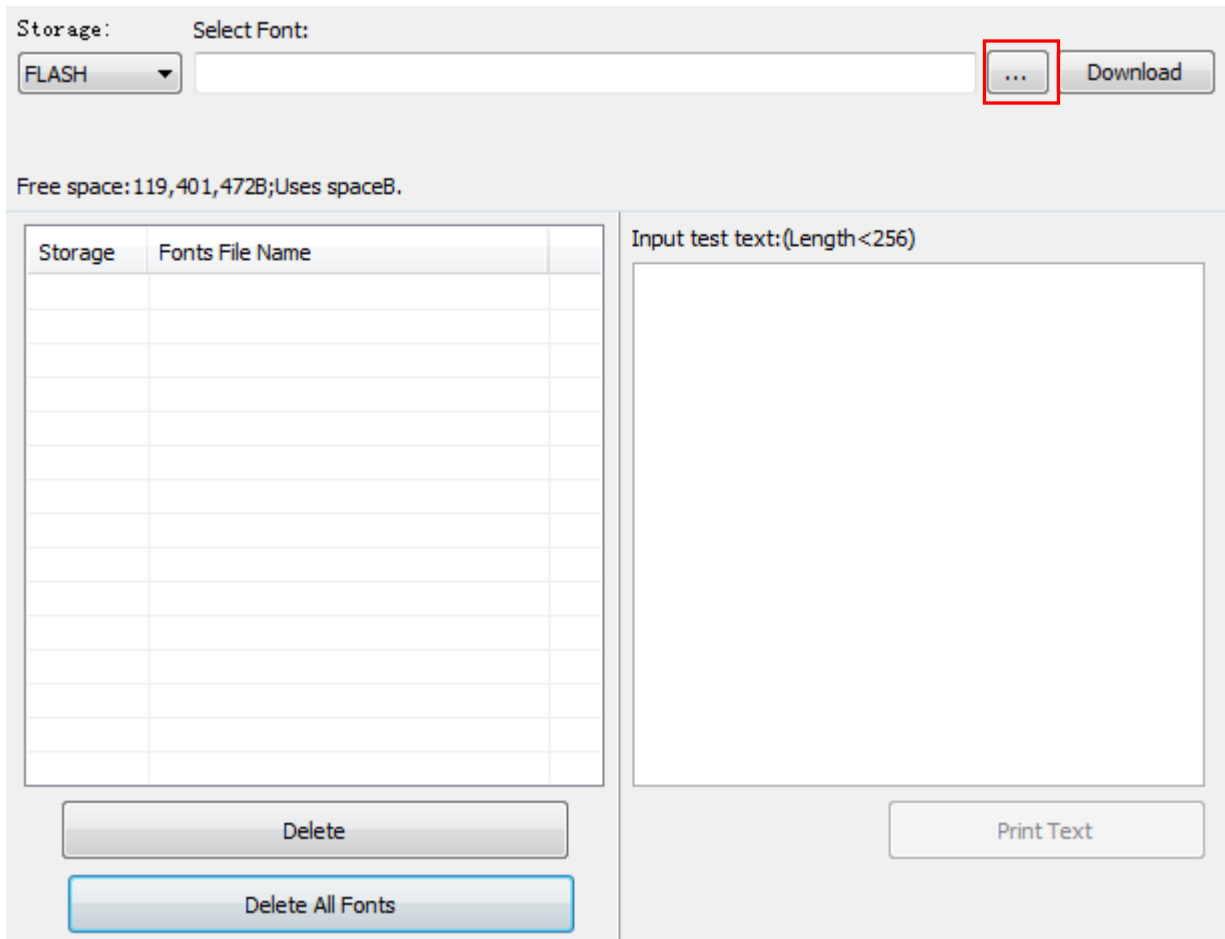

(2) Click "Download" (Note: The font file name must be in English or number).

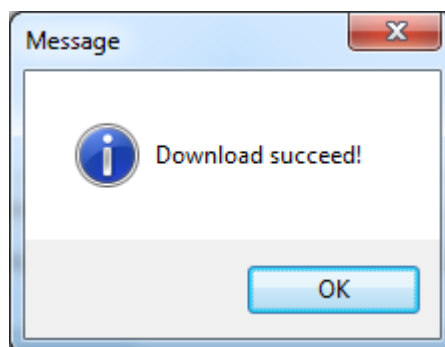
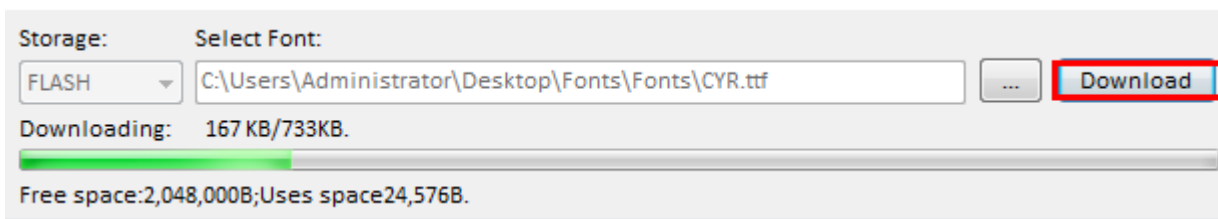

(3) Select the downloaded font file, enter the print content in the text box, and click “Print Text”.

Storage: FLASH Select Font: C:\Users\Administrator\Desktop\Fonts\Fonts\cour.ttf ... Download

Downloading: 788 KB/788KB.

Free space:1,069,056B;Uses space1,003,520B.

Storage	Fonts File Name
FLASH	COUR.TTF
FLASH	CYR.TTF

Input test text:(Length<256)  
abc123

Printable Width: 30 (10-108)mm  
Printable Height: 30 (10-210)mm

Delete  
Delete All Fonts  
Print Text

5. Click "Function Test". User can carry the followings such as sensor calibration, pattern print testing and so on.

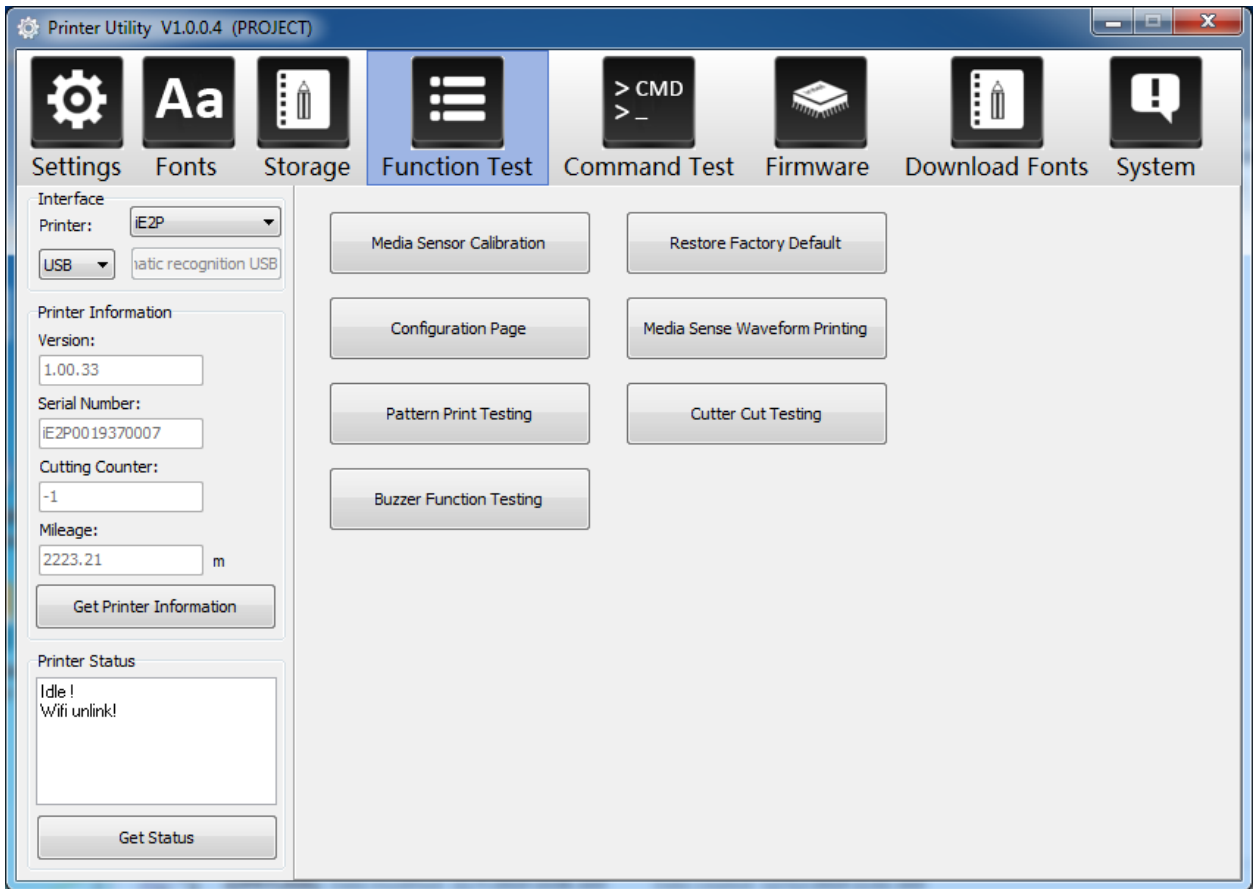

6. Click on "Download Fonts". (Users can select fonts directly from the word library provided by our division)

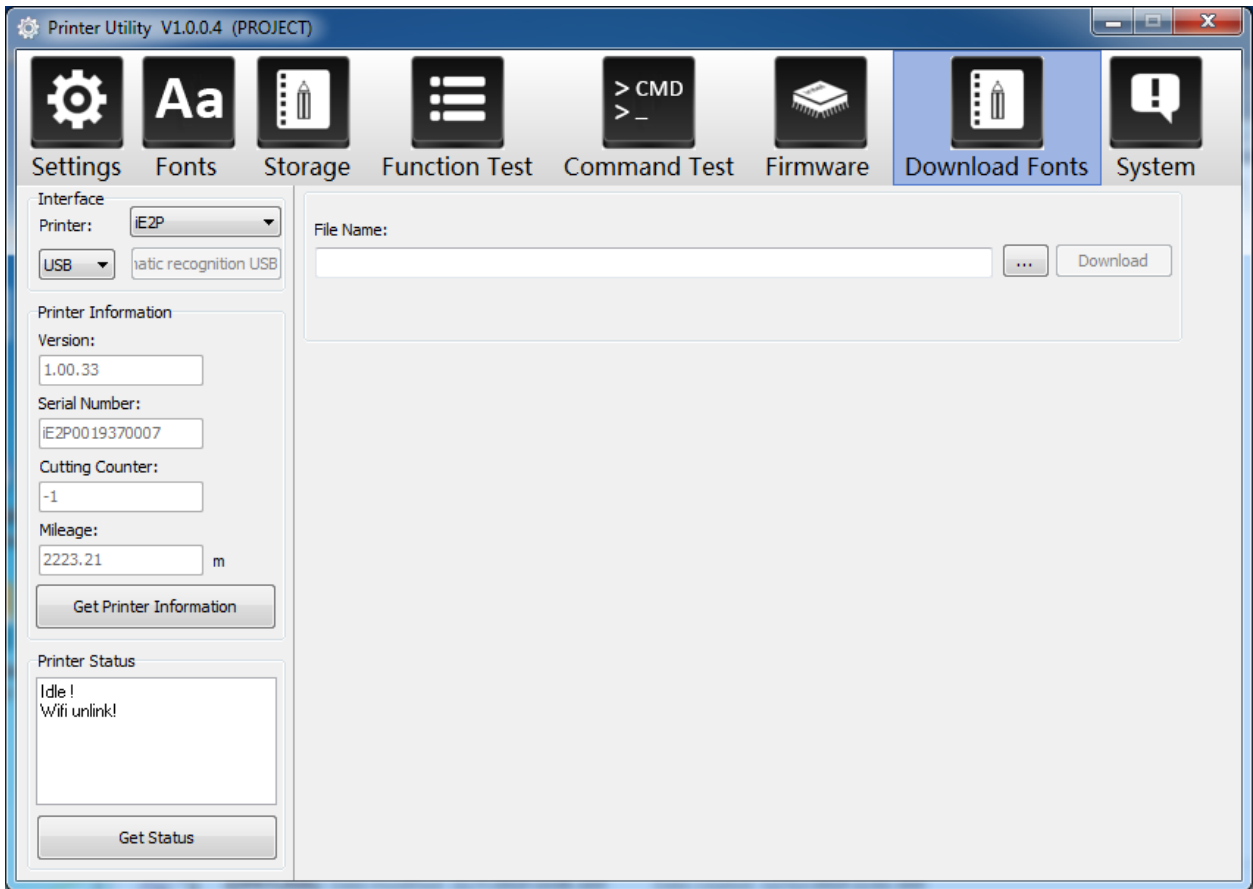



7. Click "System". Click "language" and choose the language of printer utility.

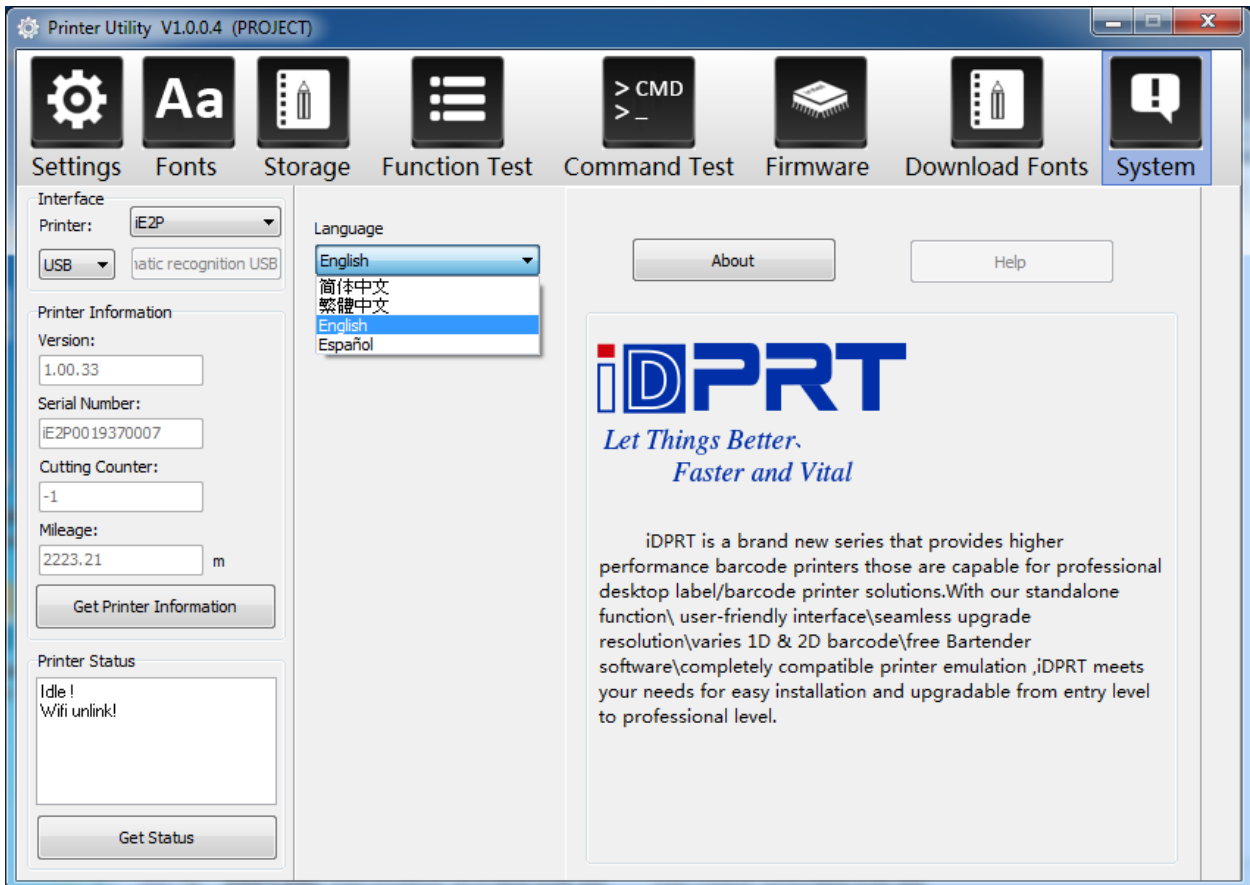

## **Chapter 7 Seagull Windows Driver Instructions**

### **7.1 Introduction**

The following operating systems are supported:

- Windows Vista, Windows 7, Windows 8 and 8.1, and Windows 10.
- Windows Server 2008, 2008 R2, 2012, 2012 R2, and 2016.
- 32-bit and 64-bit (x64) editions.

### **7.2 Installation Preparation**

Download Seagull Windows Driver application program in CD.

## 7.3 Installation



Note:

- Under different operating systems, the screen may be slightly different. Take Windows 7 as example.
- Take printer iE2P as example. Please refer to printer iE2P when using printer iE2X.
- To avoid the prevention, recommend to close the security software before installation.
- All of the following settings if you want to restore to the original state of the printer can only be restored by factory settings

1. Select one interface to connect your printer to computer.
2. Turn on the printer and check if it is connected to computer successfully.



3. Double click Seagull Windows Driver.
4. Read and agree the license agreement. Then click "Next".

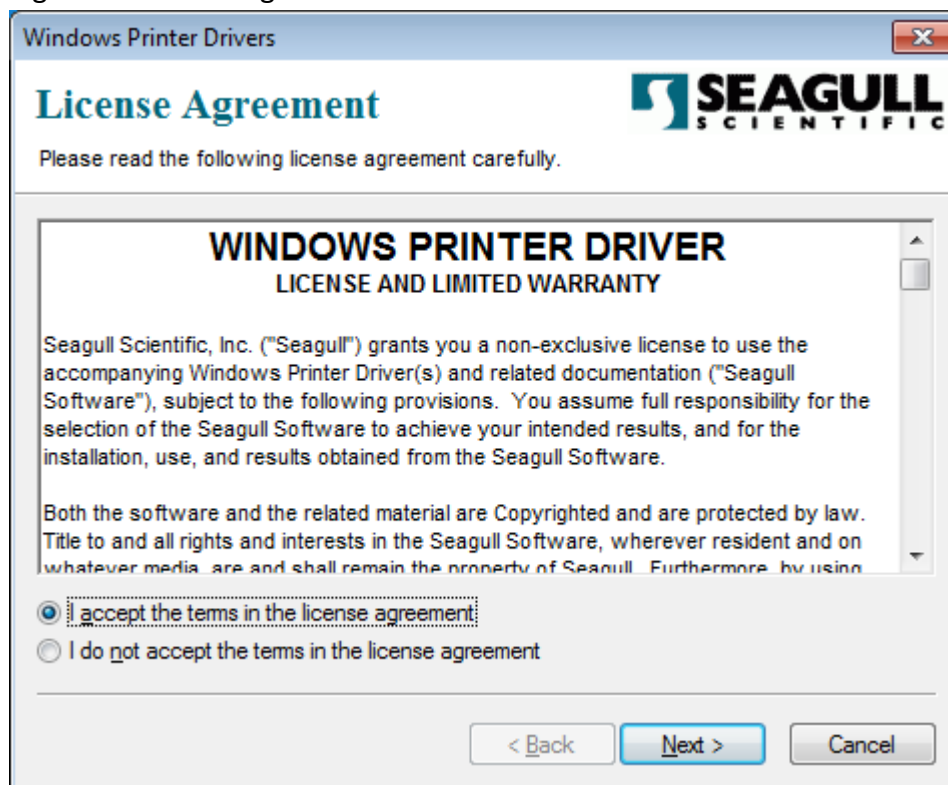

5. Choose the installation directory, then click "Next".

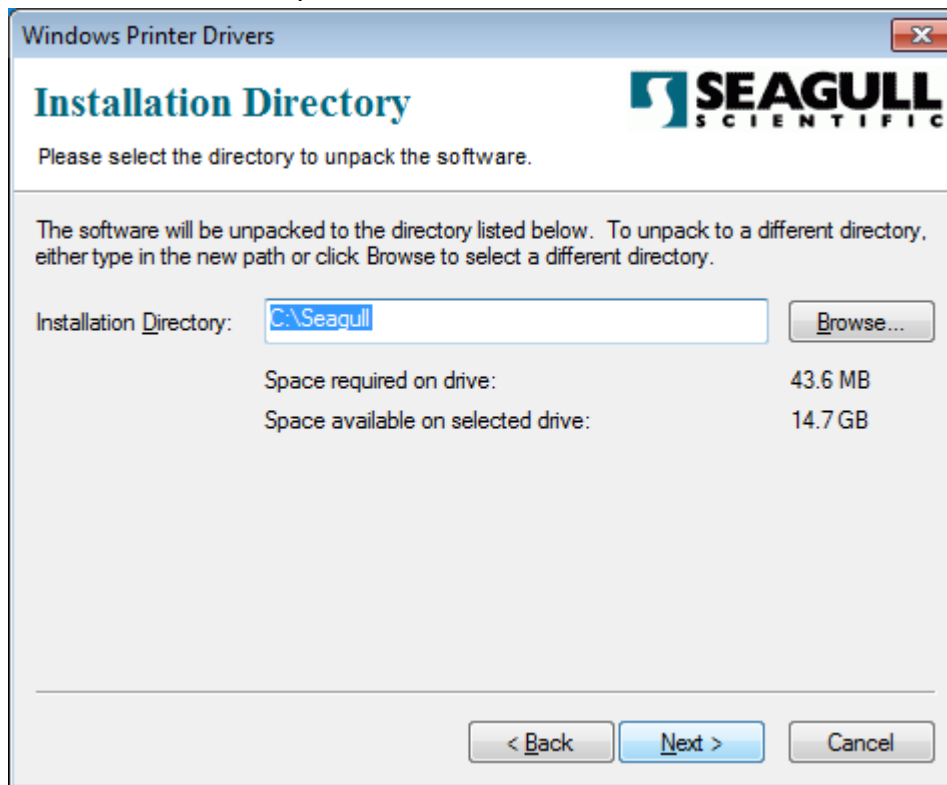

6. Click "Finish".

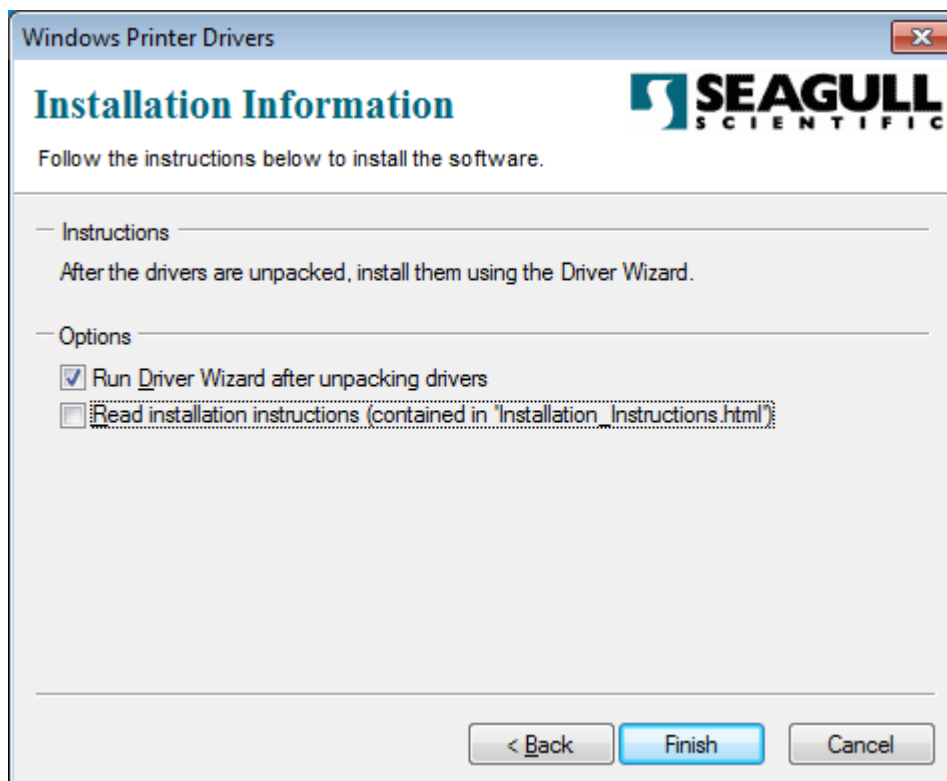

7. Choose "Install printer drivers", then click "Next".



**Note:** If you have connected the printer to computer, it will detect and install the driver automatically. (e.g. USB port)

8. Choose the printer, then click "Next".

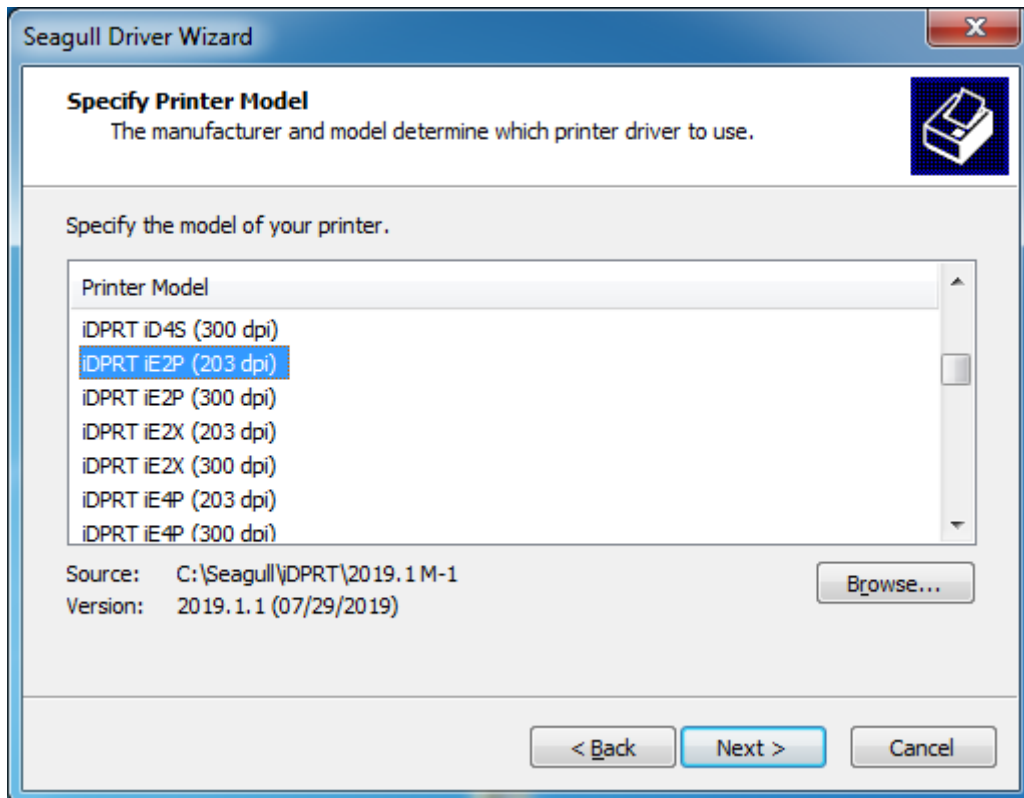

9. Enter a name for this printer, then click "Next".

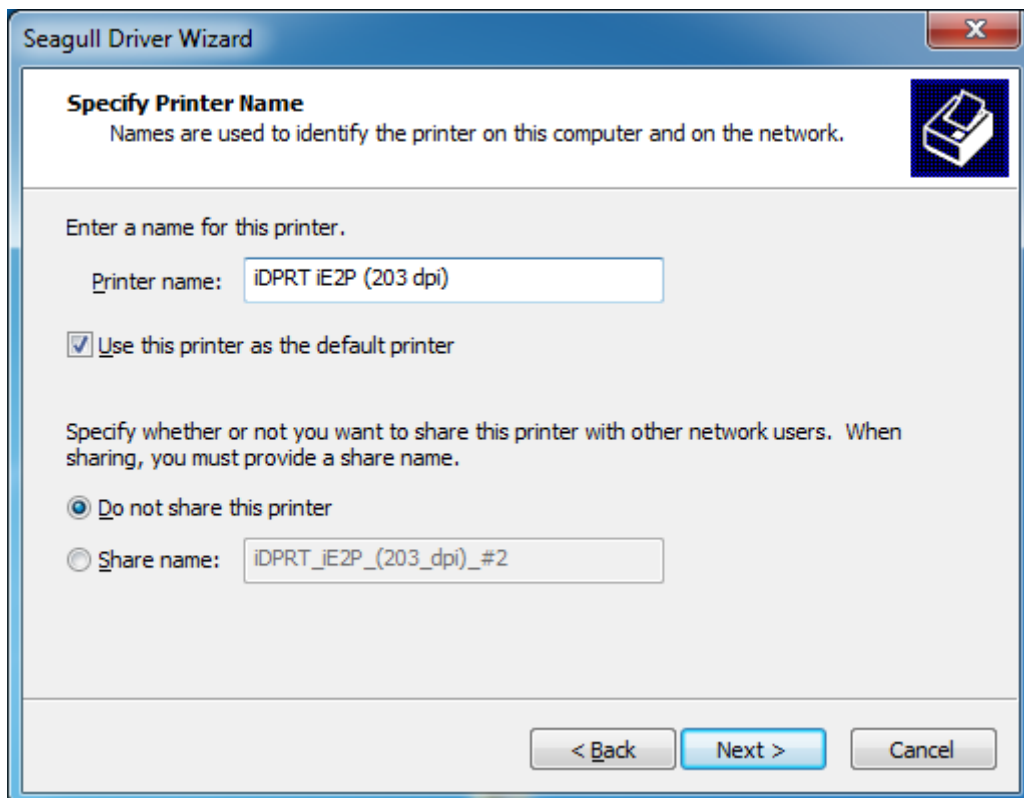

10. Click "Finish".

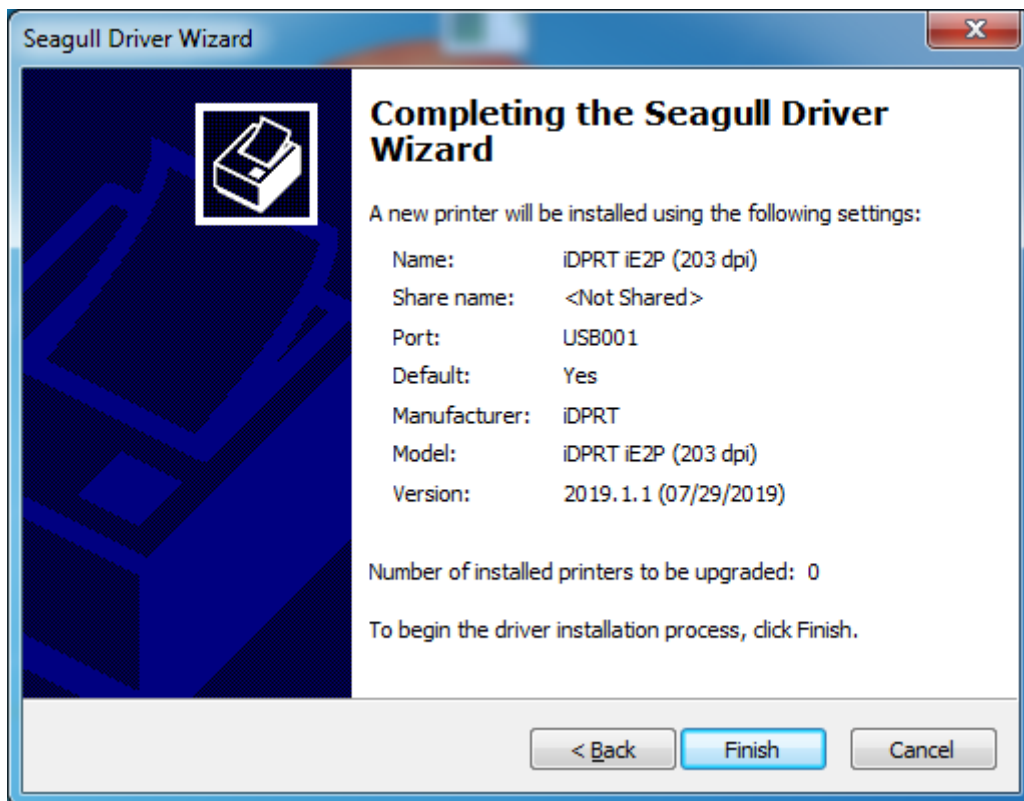

11. Click "Close", and the driver is installed successfully.

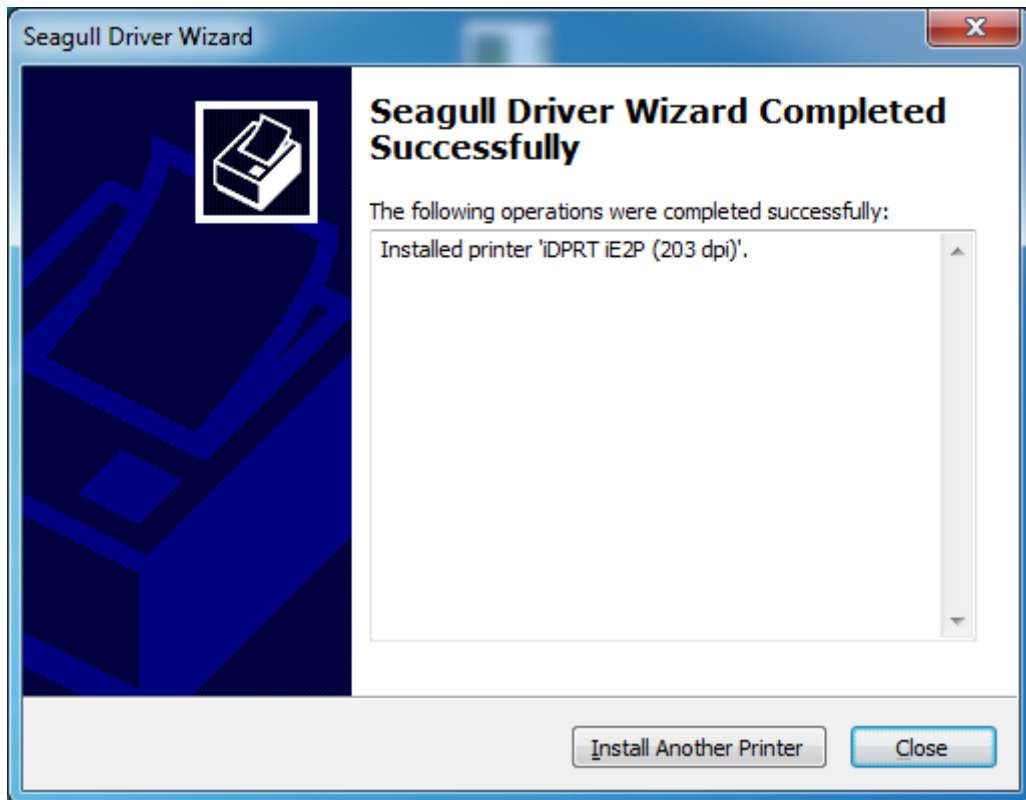

12. After installation, the icon will be found in "Start" → "Devices and Printers".



**Note:**

- If you have already installed the driver (No matter what kind of ports), it will generate a USB port automatically when connecting the printer to computer.
- Any problems exist, please use our utility tool in CD.



## 7.4 Usage

### 7.4.1 Printing Preferences

1. Click "Start" → "Devices and Printers". Right click icon and choose "Printing preferences".

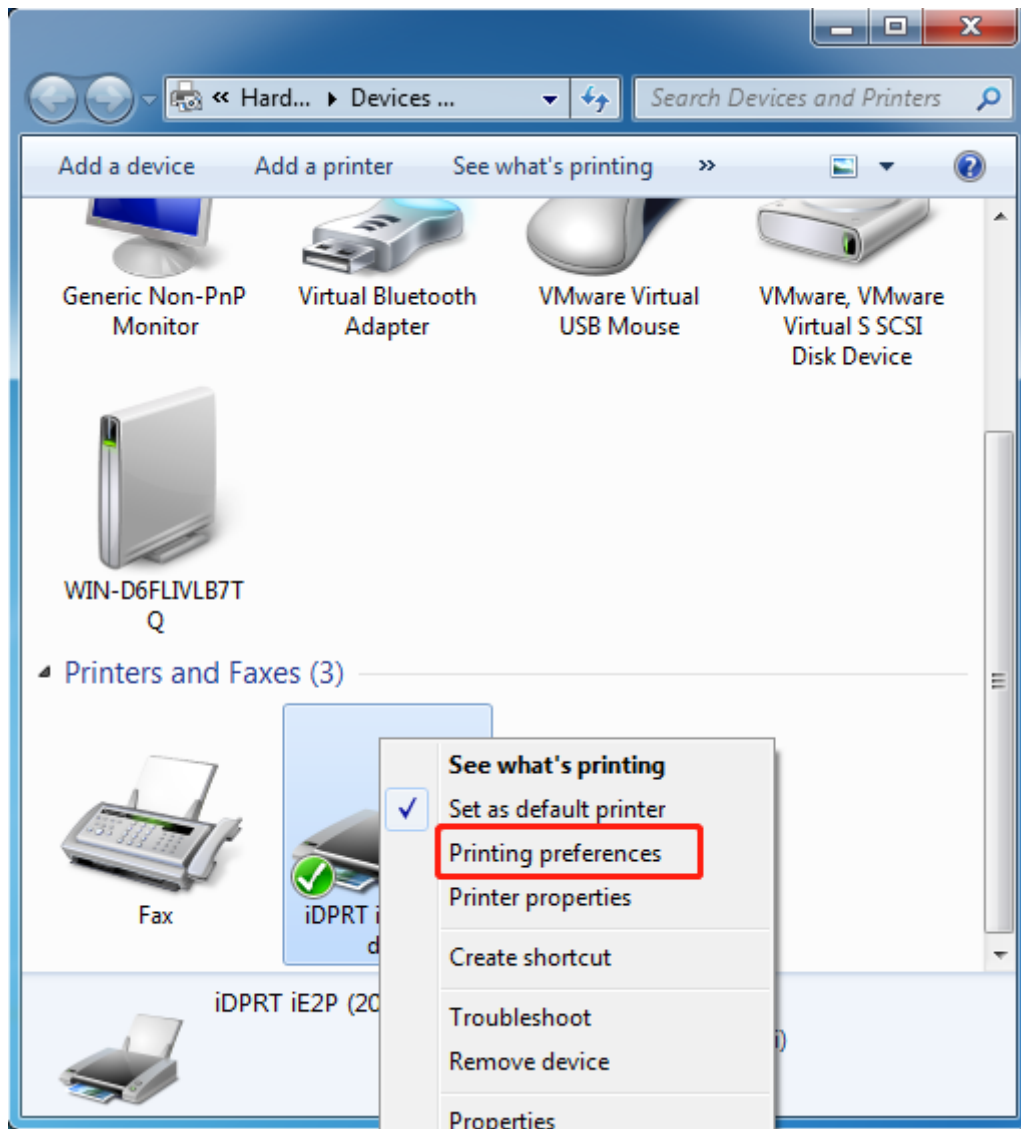

2. According to different needs, set up the page.

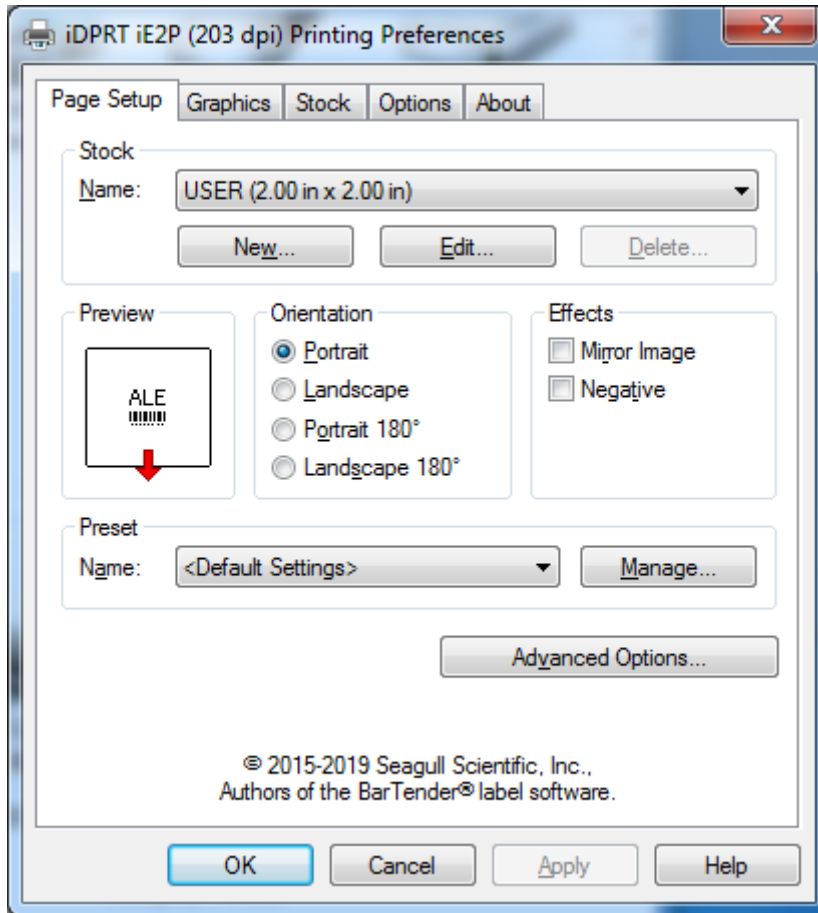

- Click “Stock” → “Name”, and choose the paper type.

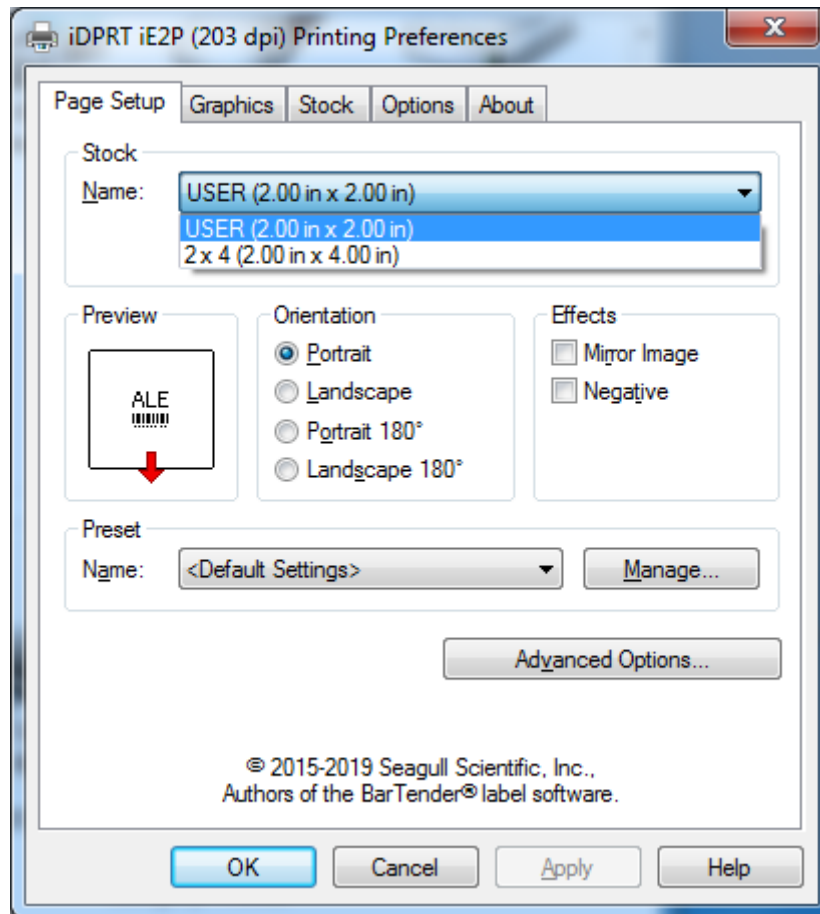

- Click “New Stock”, and set up a new stock.

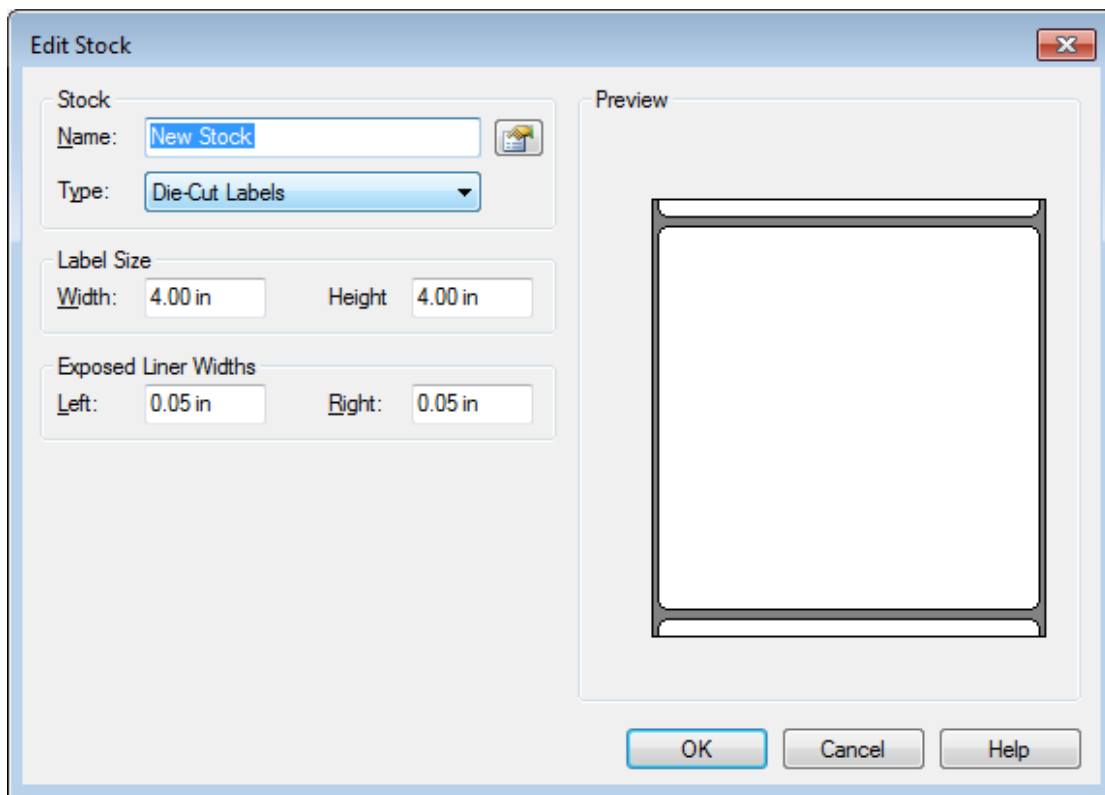

- Click “Edit Stock”, and edit the stock.

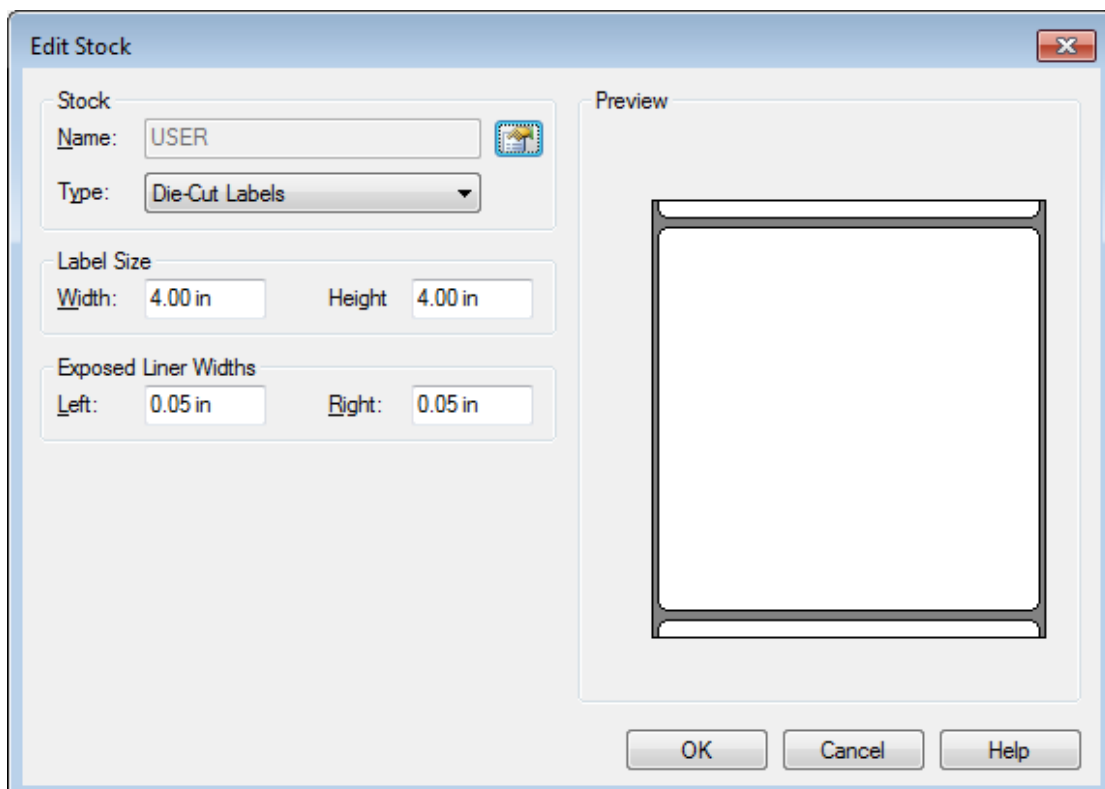

- Choose “Orientation” or “Effects”, showed in the “Preview”.

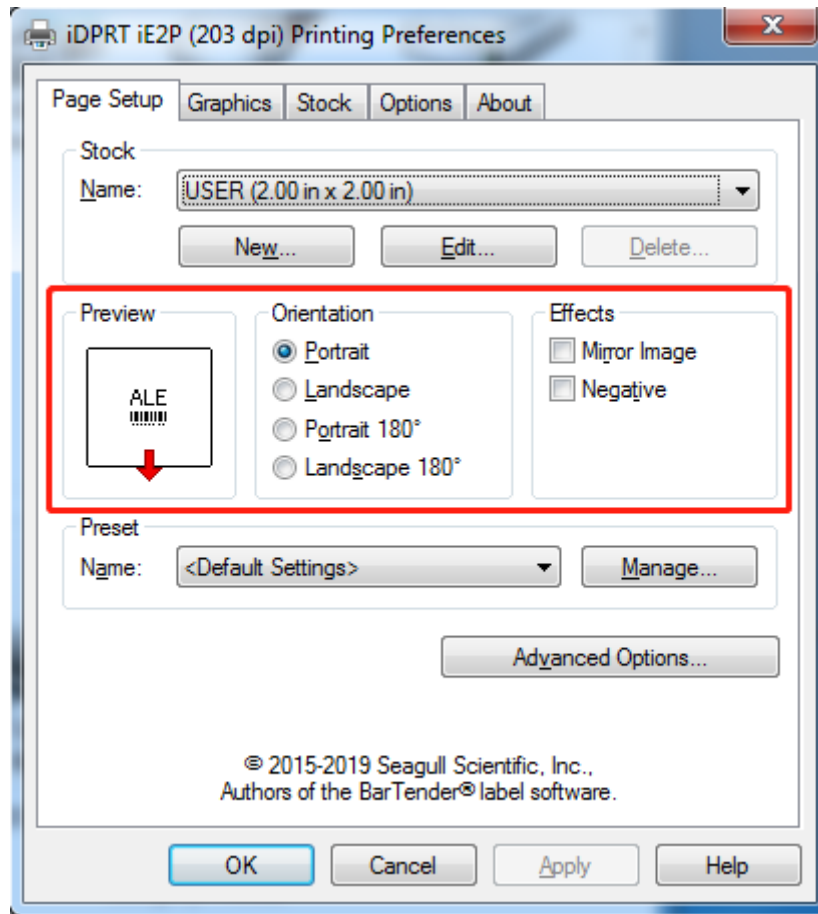

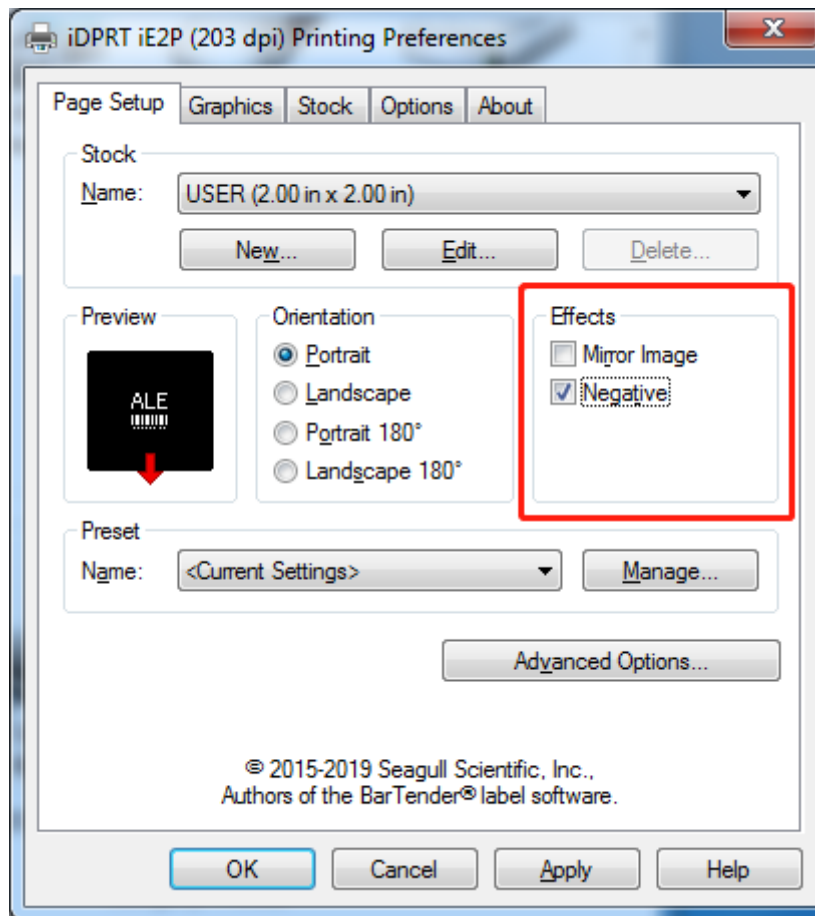

- Click “Preset” → “Name”, and back to the default settings.

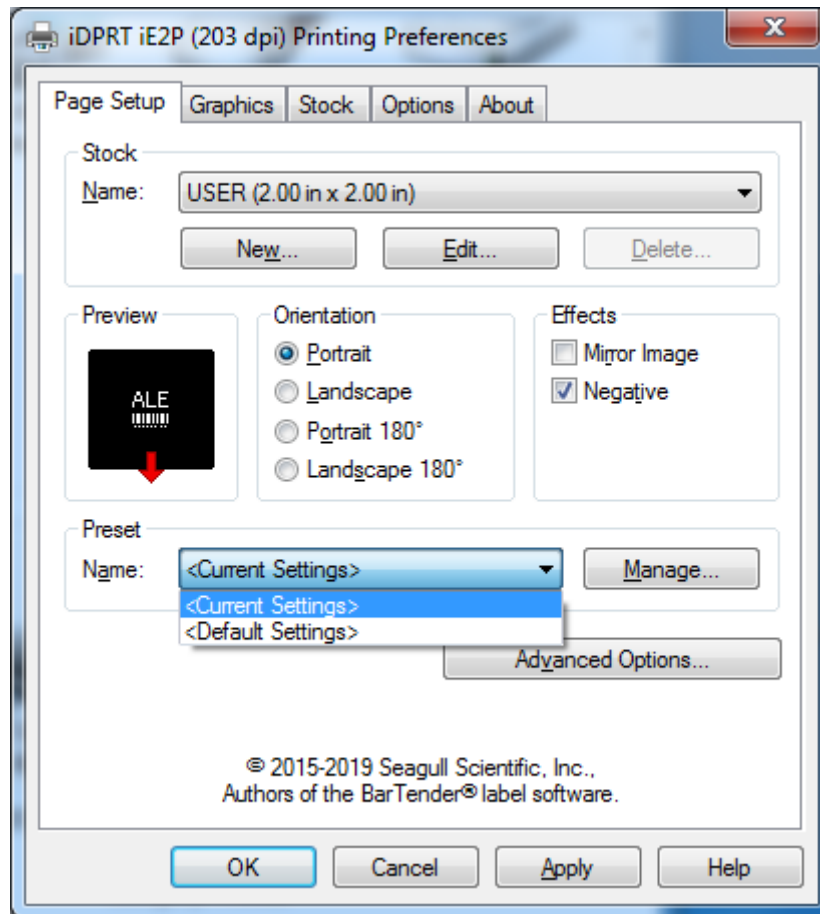

- Click “Manage”, and change the settings.

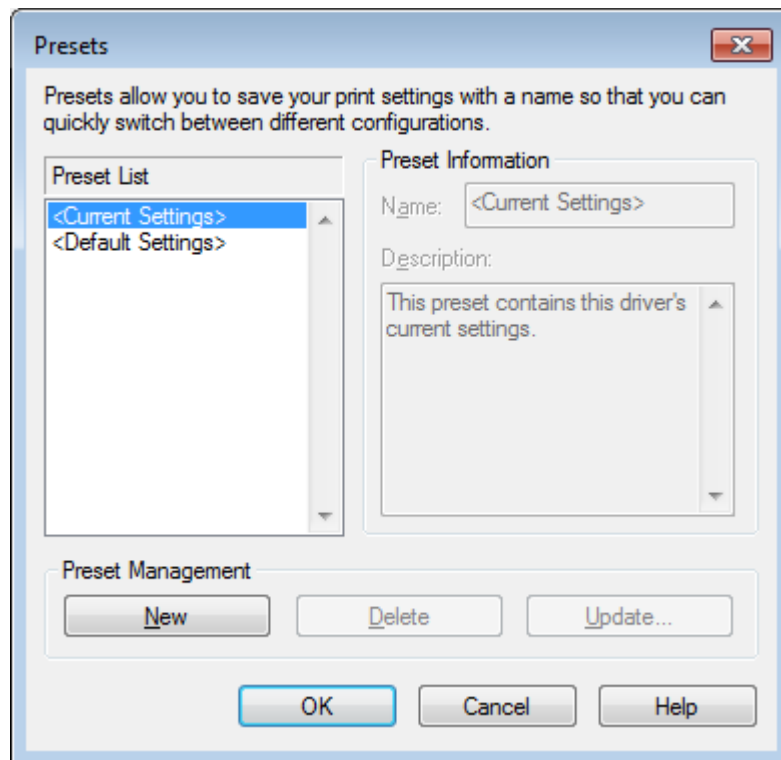



3. Click “Graphics”, and edit the pictures.

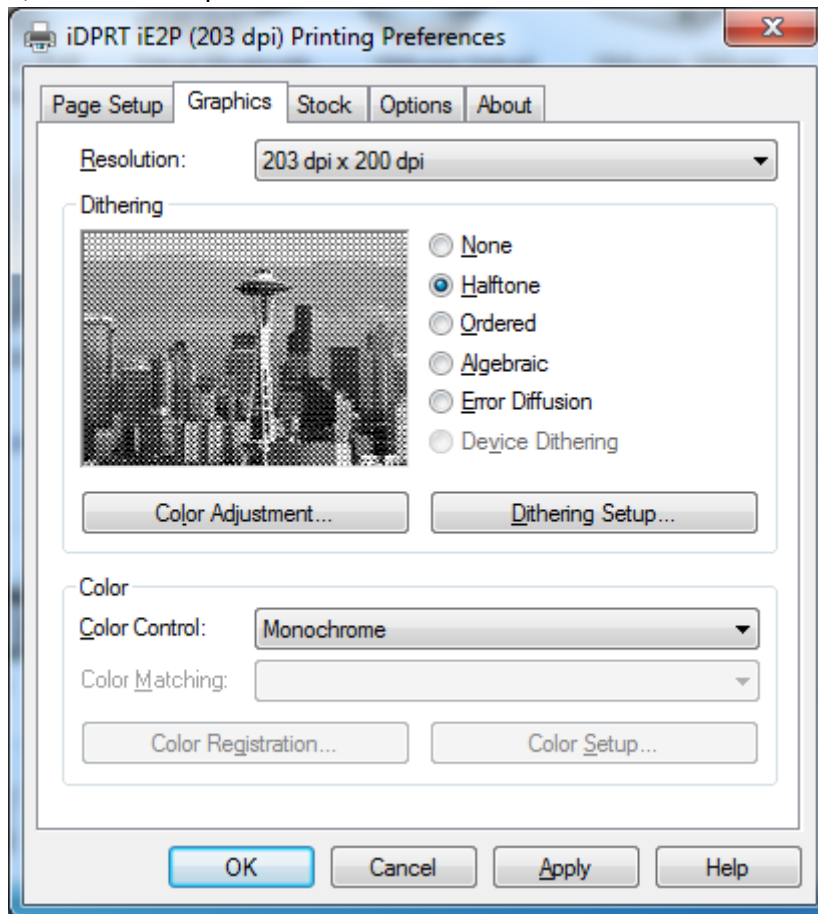

4. Click “Stock” to set the media settings, feed mode and feed options.

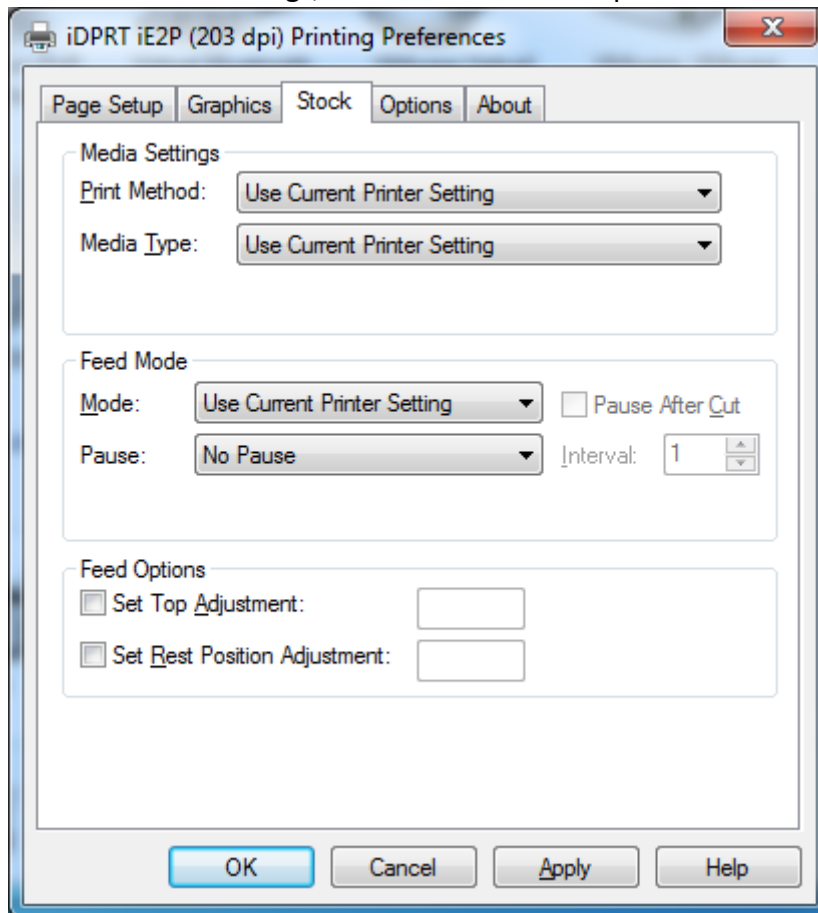

- Set up the print method.

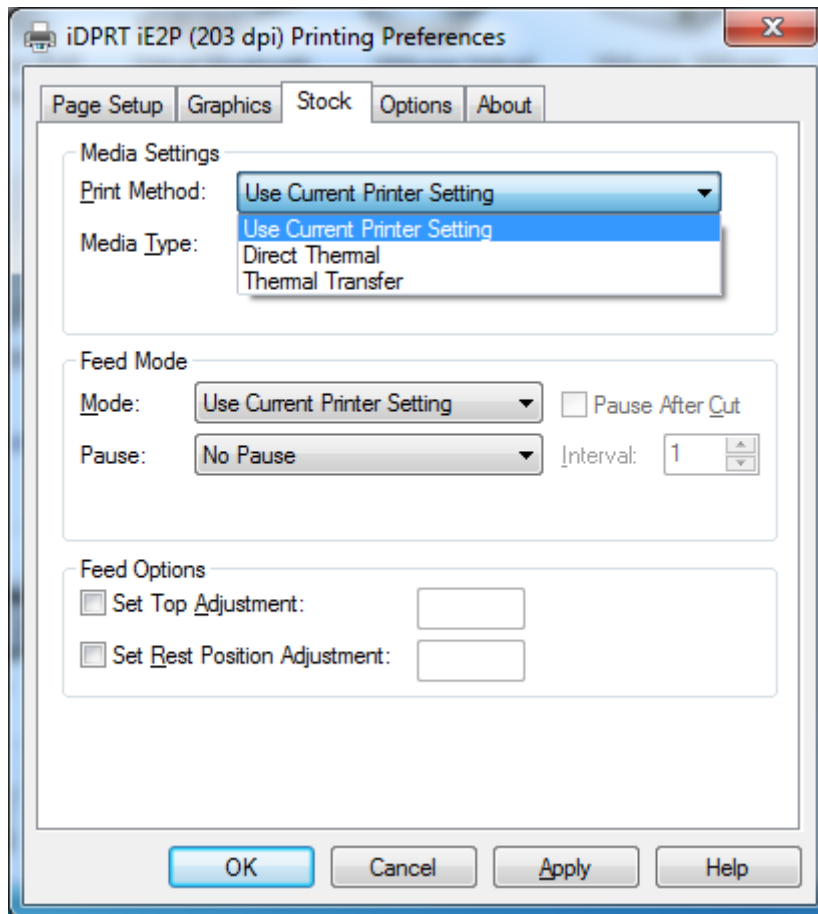

- Set up the media type.

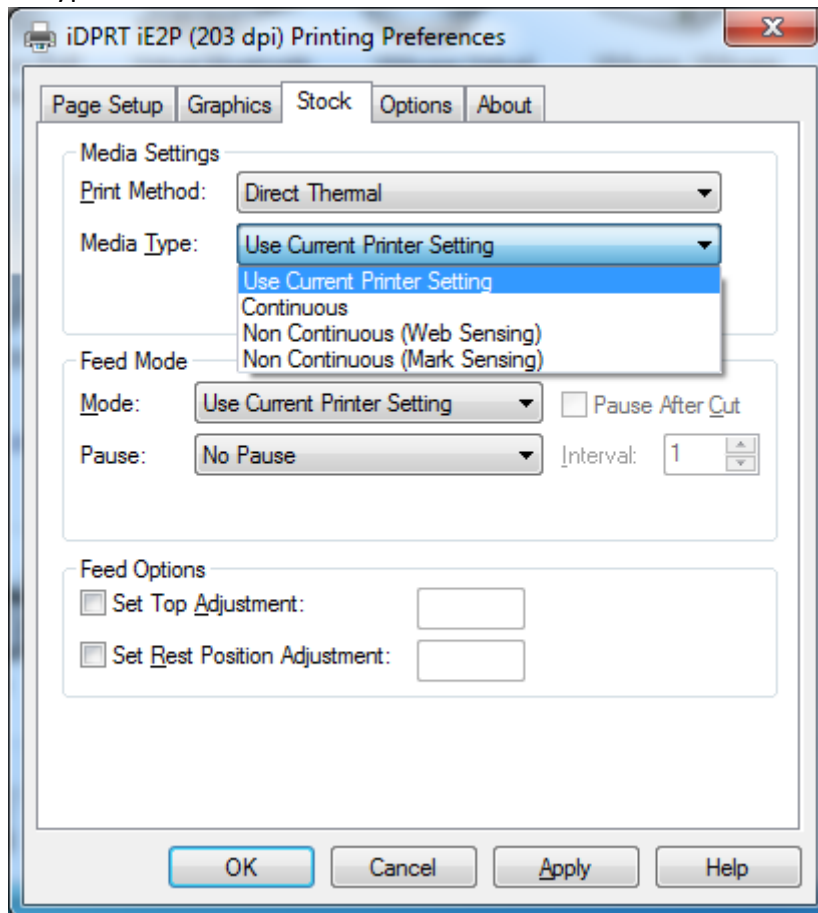

- Click “Feed Mode” → “Mode”, and choose the method of media handling.

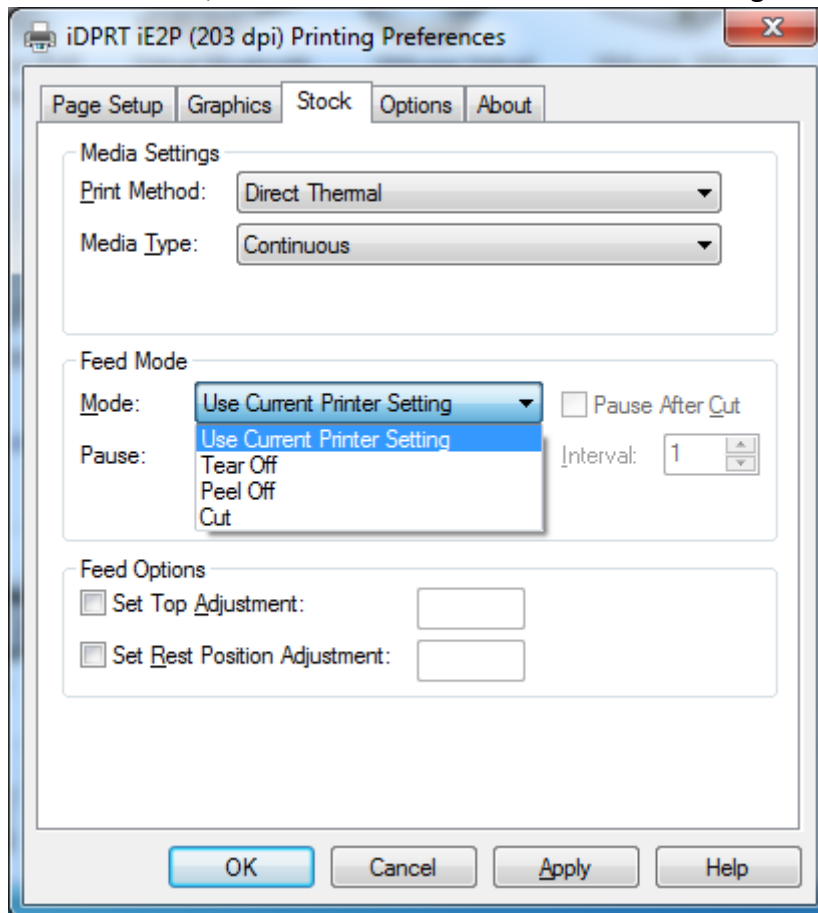

5. Click "Options" to set the darkness and speed.

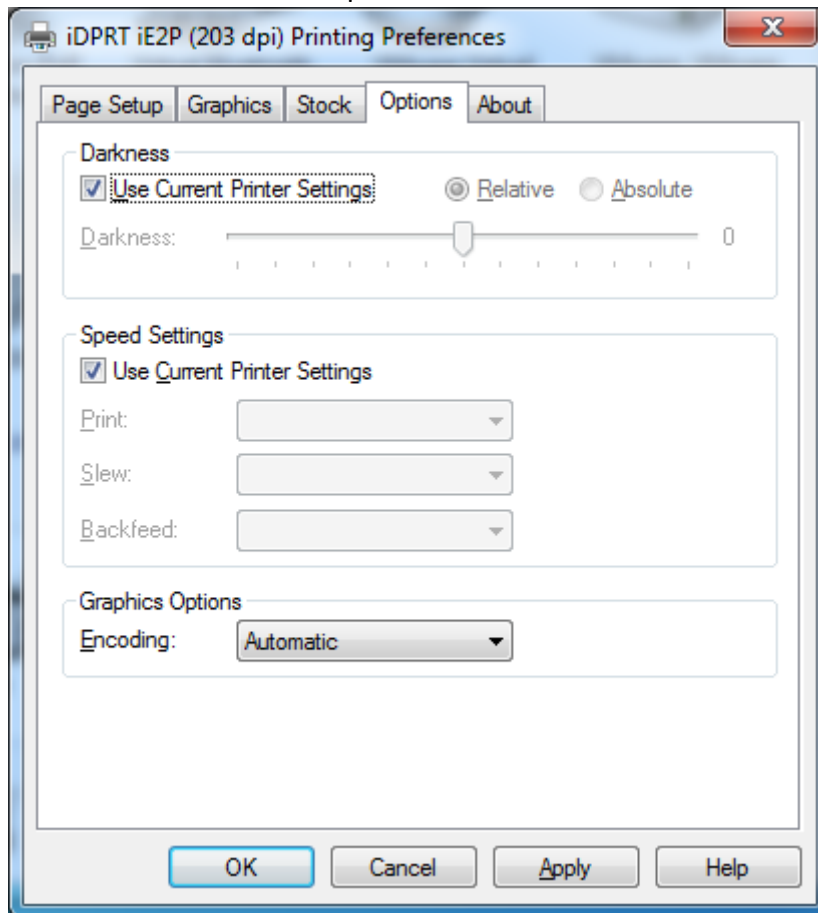

## 7.4.2 Printer Properties

1. Click “Start” → “Devices and Printers”. Right click the icon and choose “Printer properties”.

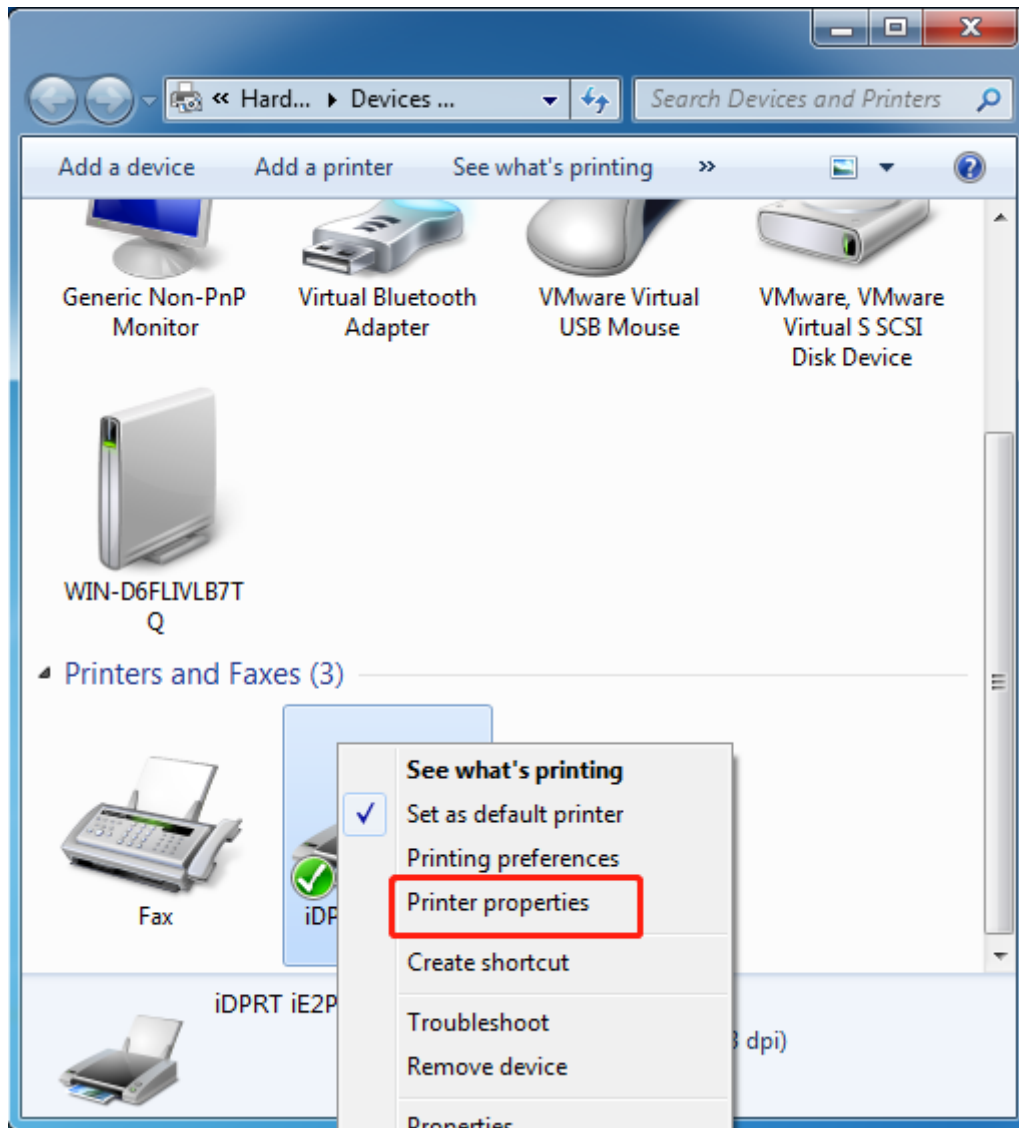

2. Click “General” → “Print Test Page”, and printer will print labels with current settings.

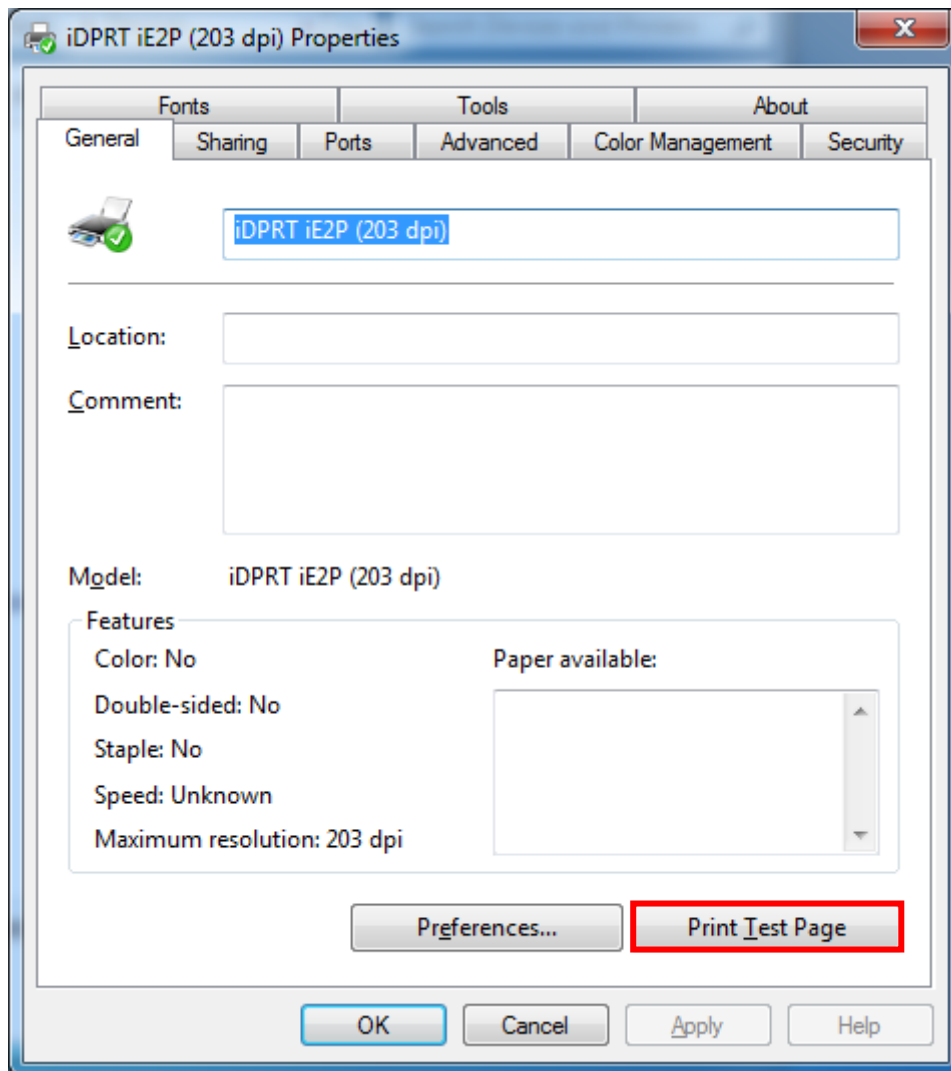



3. Click "Ports", and choose the port needed.

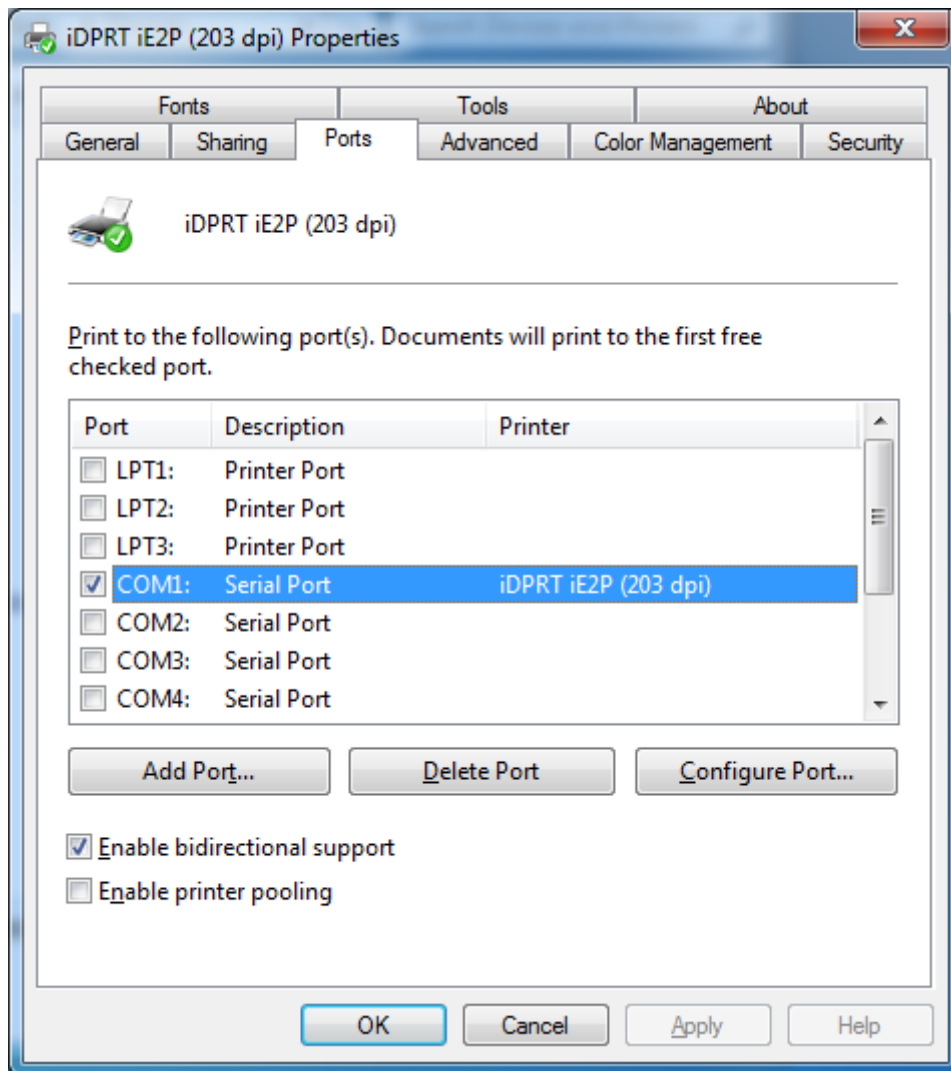

4. Click "Advanced" to set the available time for printer.

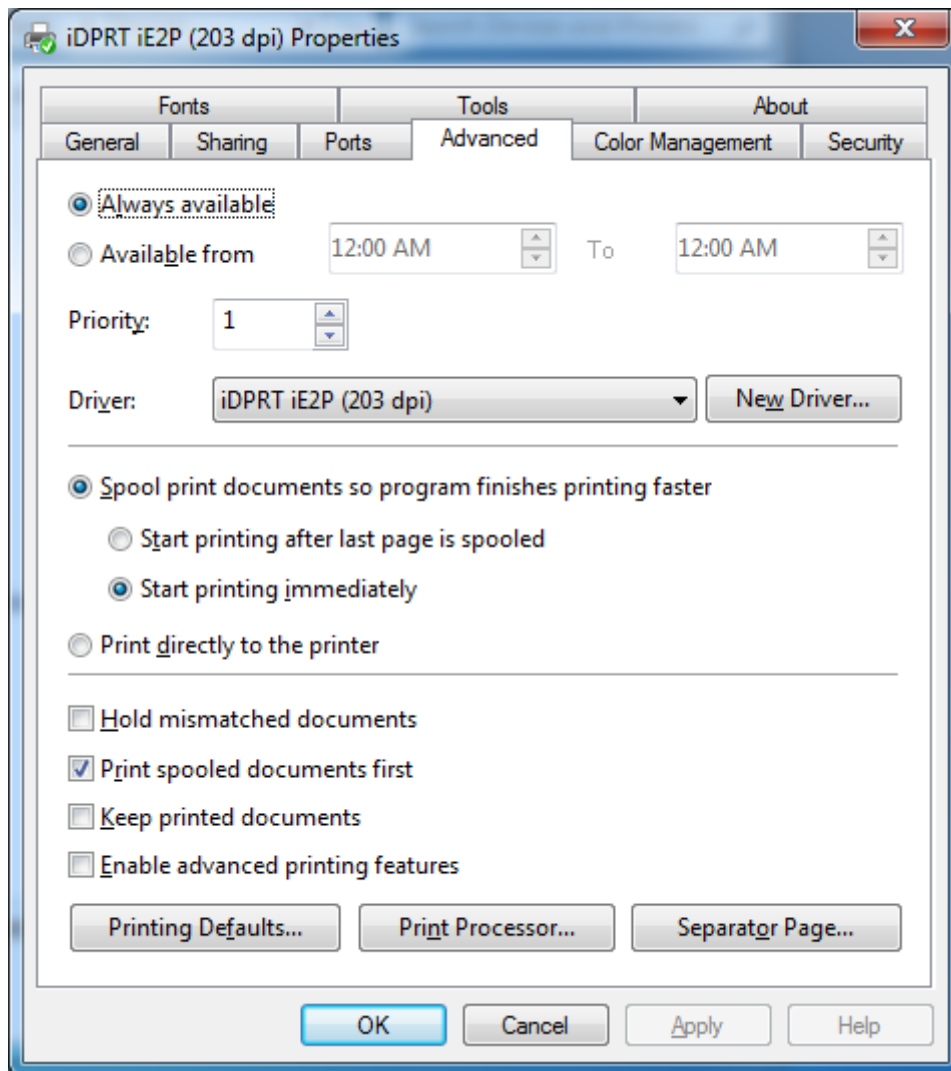

5. Click "Tool" → "Action" to set all settings into the restore factory setting.

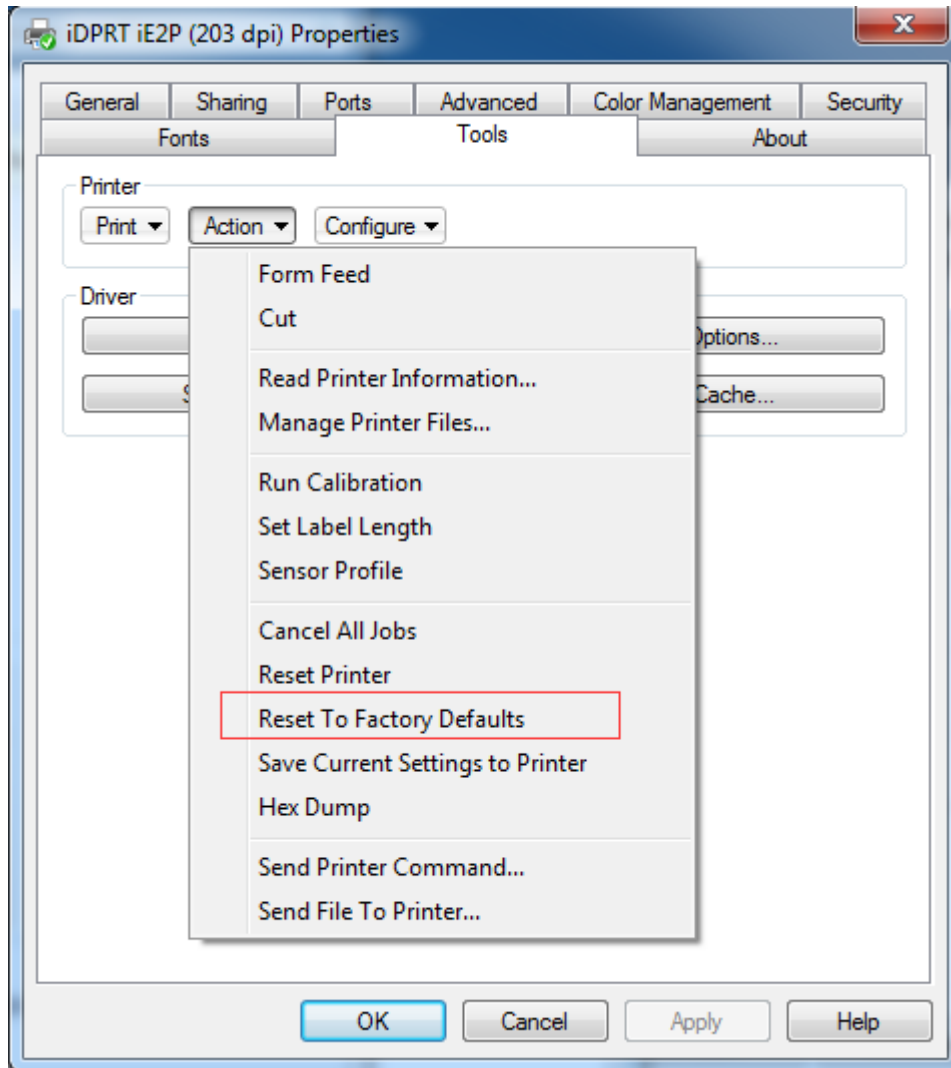

## **Chapter 8 BarTender Ultralite Instructions**

### **8.1 Introduction**

This chapter provides instructions on BarTender Ultralite program according to PC operating systems (OS).

The followings are supported.

- Windows 10, 8.1, 8, 7 and Vista.
- Windows Server 2016, Server 2012 and 2012 R2, Server 2008 and 2008 R2.
- Includes all 32-bit and 64-bit (x64) editions.

### **8.2 Installation Preparation**

Download BarTender Ultralite application program in CD.

## 8.3 Installation



Note:

- Under different operating systems, the screen may be slightly different. Take Windows 7 as example.
- Take printer iE2P as example. Please refer to printer iE2P when using printer iE2X.
- To avoid the prevention, recommend to close the security software before installation.

1. Double click the application program .

2. Select language, then click "OK".

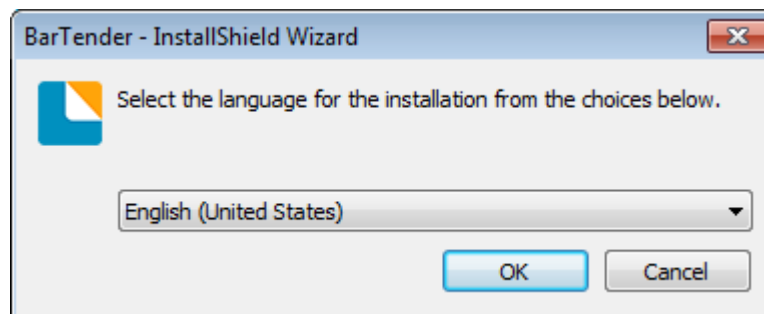

3. Click "Install".

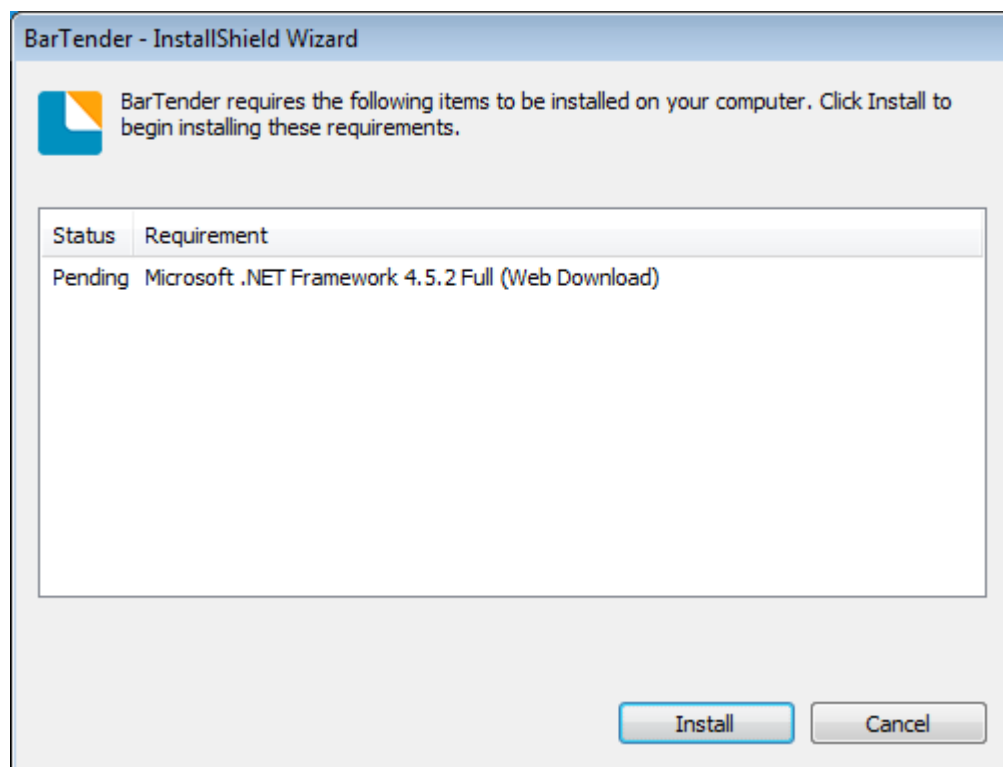

4. Click "Next".

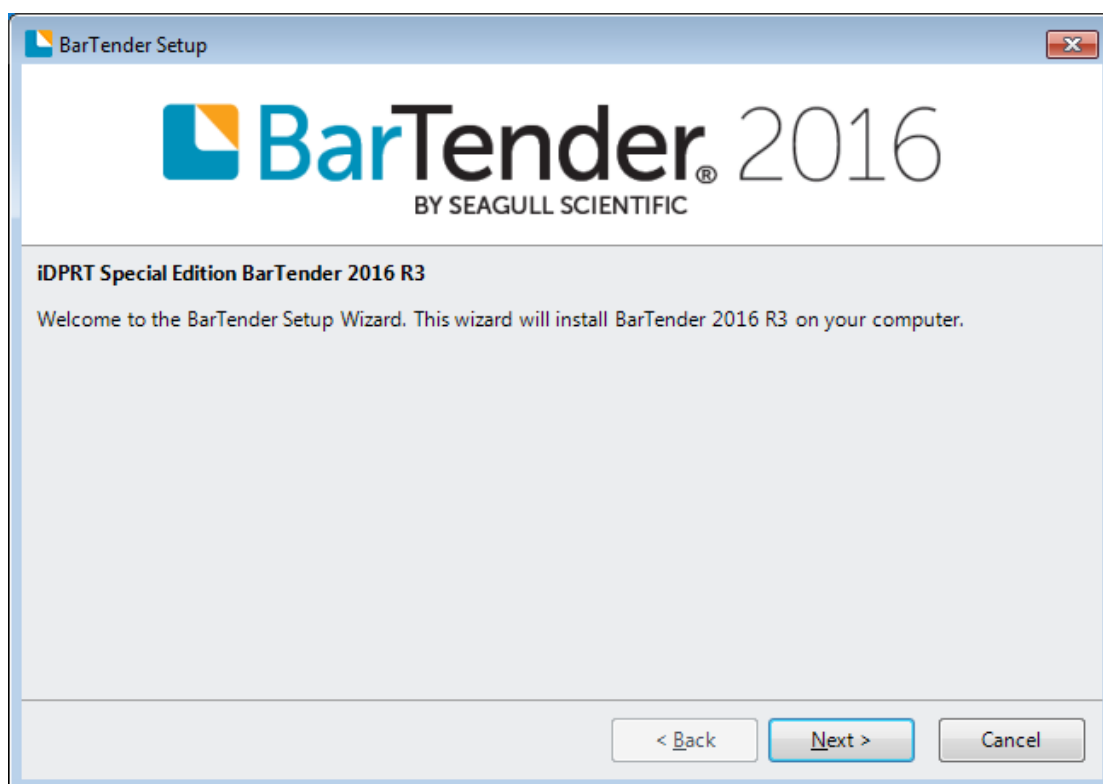

5. Read and accept the license agreement, then click "Next".

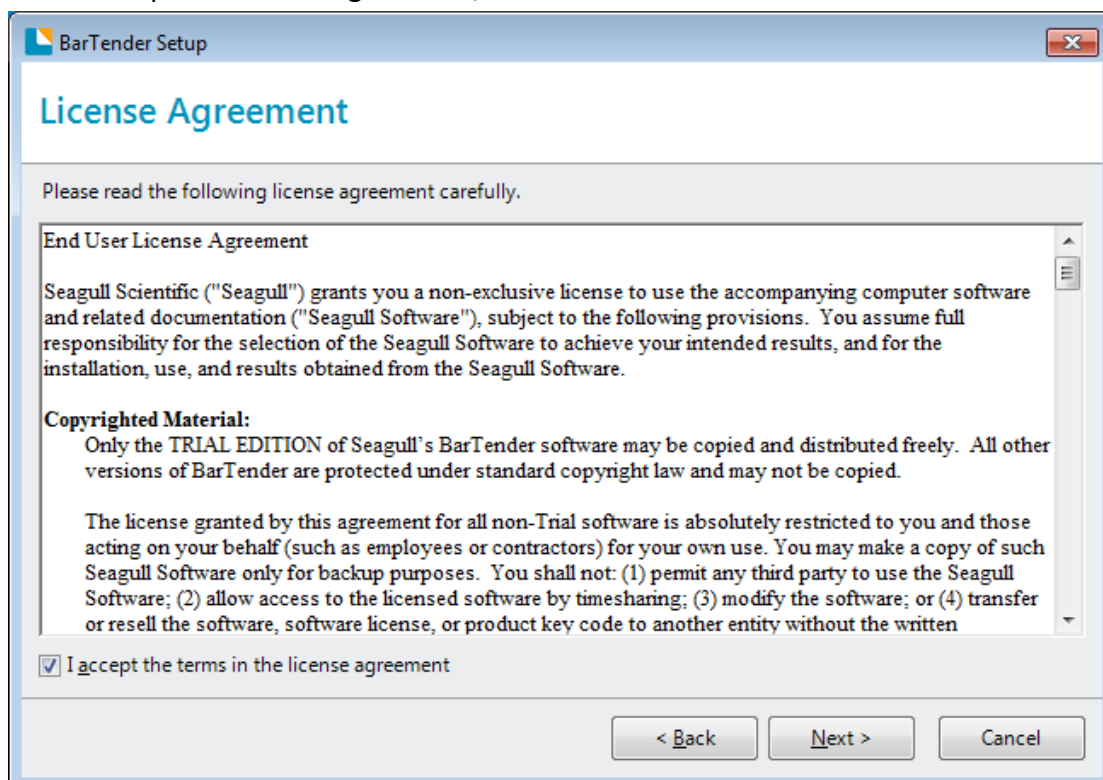

6. Select "Features" and installation location, then click "Next".

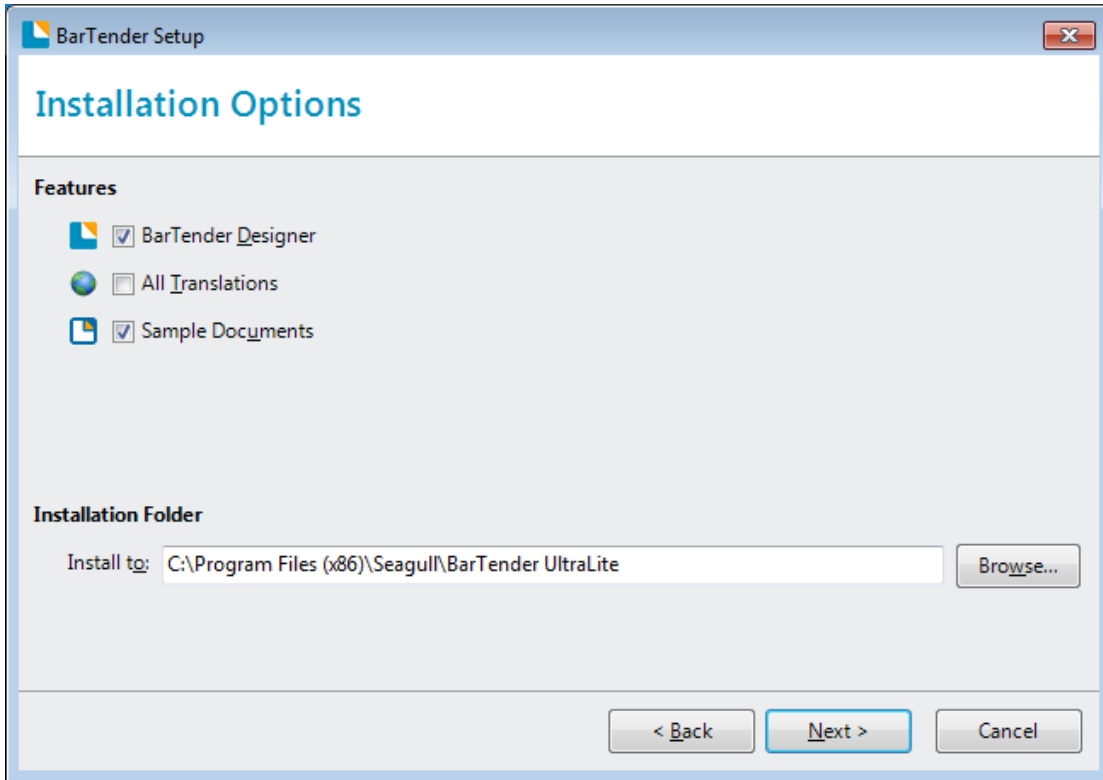

7. Click "Install".

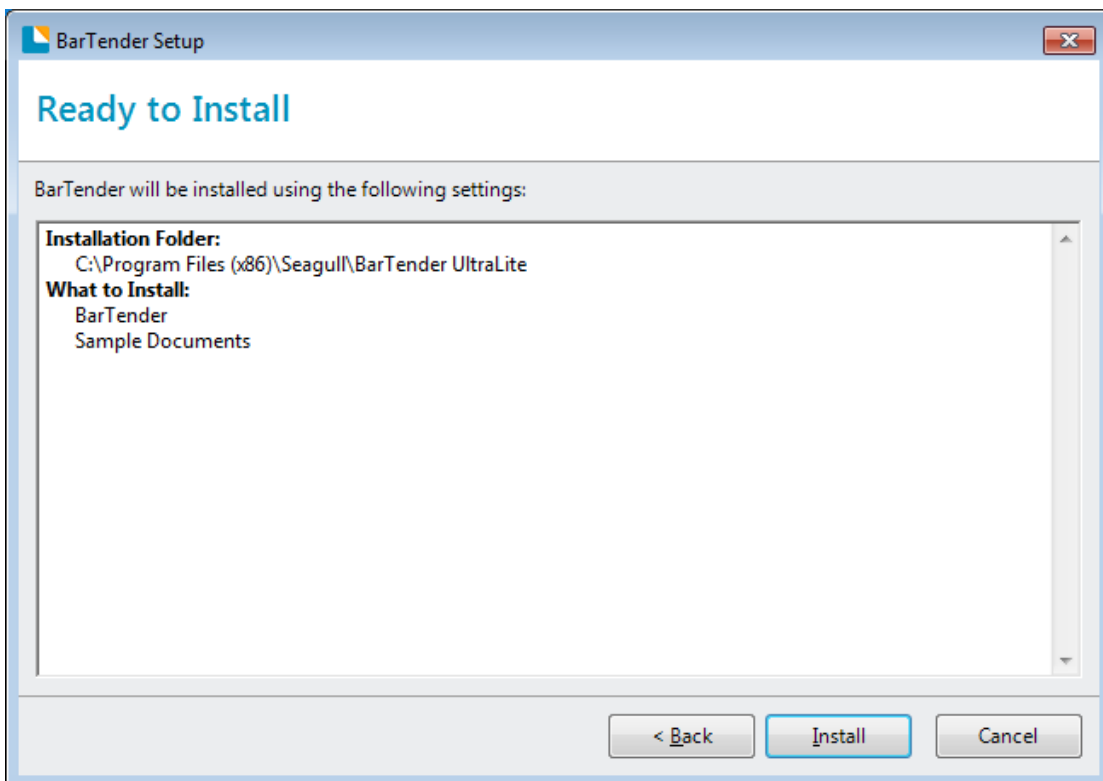

8. Click "Finish".

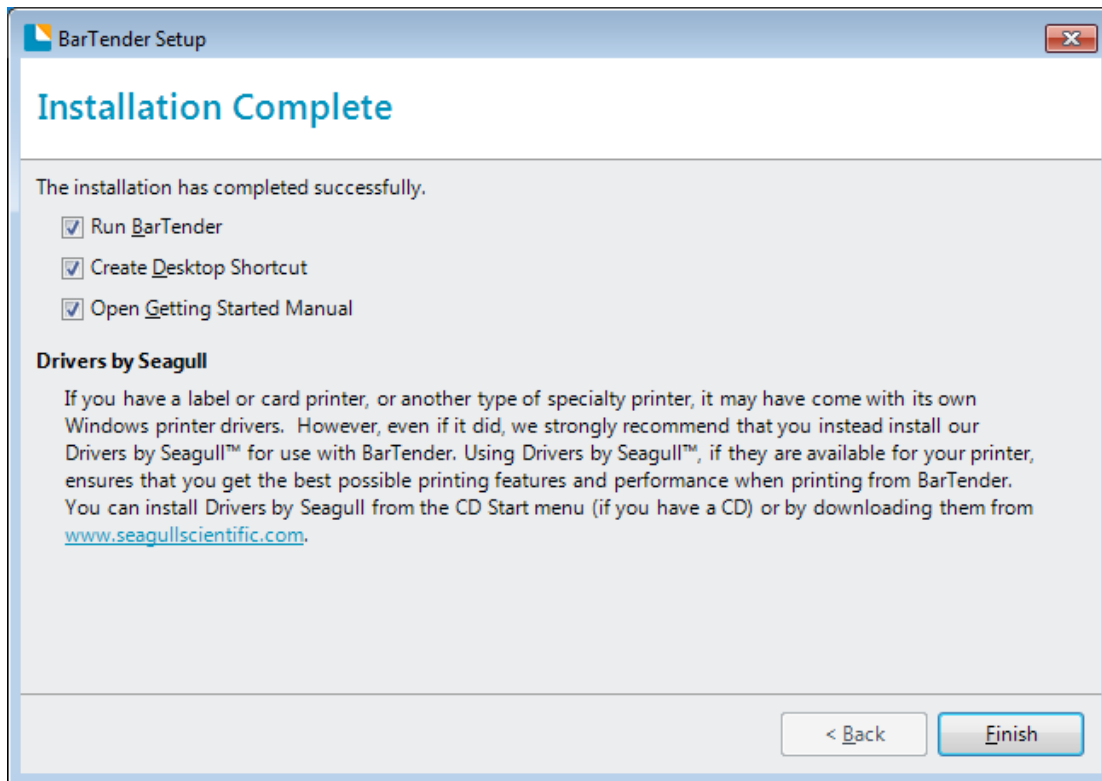

9. Back to desktop, and you will see the icon of BarTender Ultralite. Double click it and get down to use.

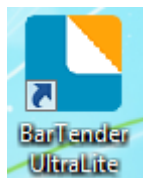



## 8.4 Usage

### 8.4.1 Page Settings

1. Double click the icon, then choose the edition. Click "OK". (The edition may be changed according to different needs.)

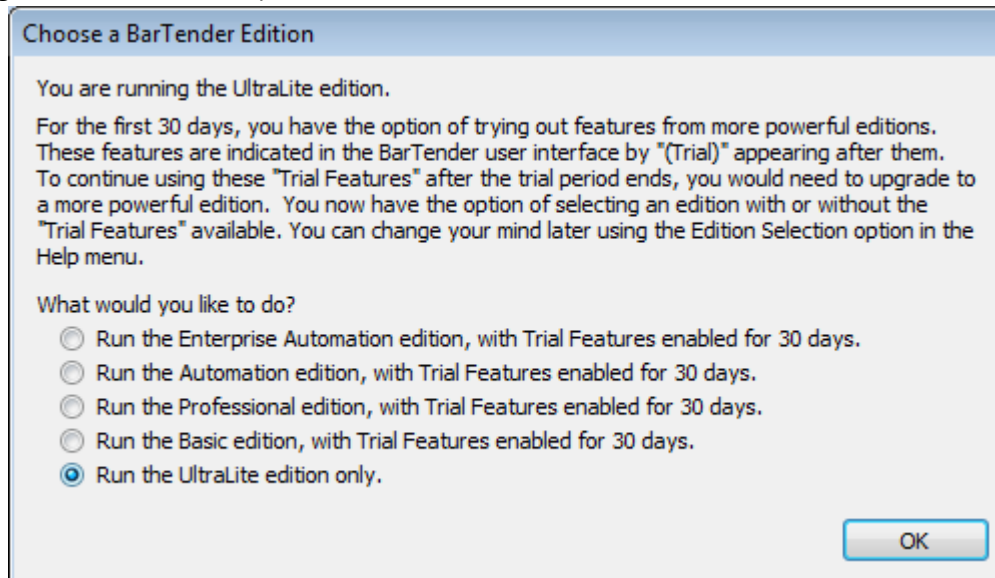

2. Click "Start a new BarTender document".

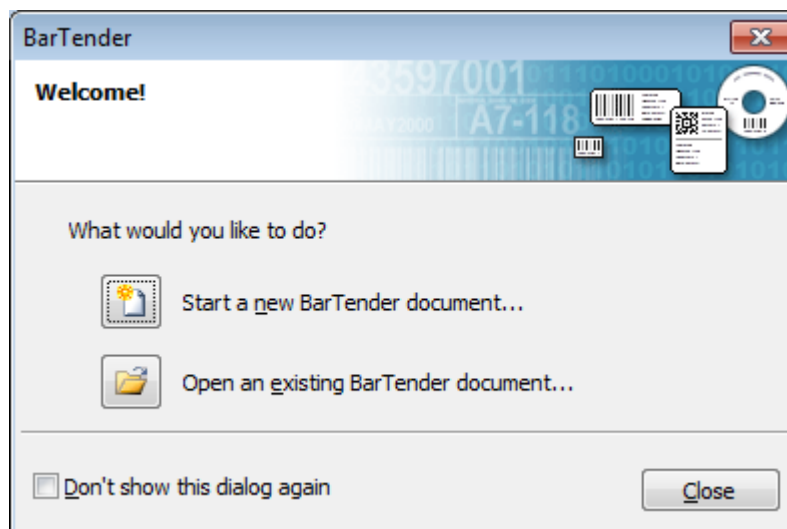

3. Choose “Blank Template”, then click “Next”.

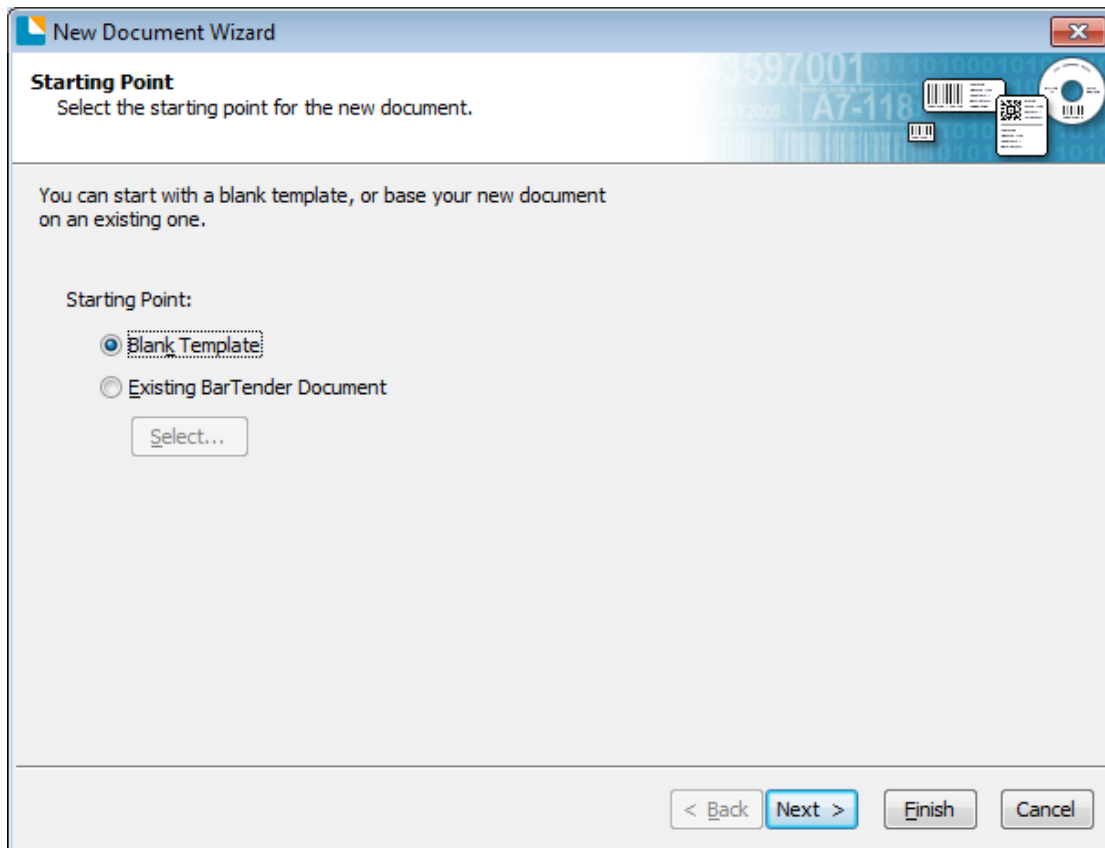

4.If the predefined stocks don't meet your need, tick "Specify Custom Settings". Then click "Next".

The screenshot shows a window titled "New Document Wizard" with a close button in the top right corner. The main heading is "Stock Selection". Below the heading is a decorative banner with a blue background, featuring a barcode, a QR code, and a CD icon. Text on the banner includes "3597001", "A7-118", and "A7-118".

Below the banner, a text block reads: "A Stock specifies the size of the page, and the size, number, and position of the items on the page. You may select a predefined Stock or specify your own custom settings."

There are two radio button options:

- Specify Custom Settings:
- Use a Predefined Stock

Under "Use a Predefined Stock", there is a "Category:" label followed by a dropdown menu, and a "Stock Name:" label followed by a large empty text area with a scroll bar.

At the bottom right, there are four buttons: "< Back", "Next >", "Finish", and "Cancel". The "Next >" button is highlighted in blue.

5. Tick “Single item per page”, then click “Next”. (If you print multiple labels, tick “Multiple columns and/or rows of items per page”.)

The screenshot shows a window titled "New Document Wizard" with a close button in the top right corner. The main heading is "Items Per Page" with the instruction "Specify the characteristics of your media." Below this, there is a background image showing various media items like a label with the number "3597001", a card with "A7-118", a QR code, and a CD. The text below the image reads: "Most media has only a single item (label, card, tag, etc.) per page of stock. Some media, however, are more complex and have multiple items on a page." There are two radio button options: "Single item per page" (which is selected) and "Multiple columns and/or rows of items per page". Under the second option, there are two spin boxes: "Rows:" with the value "1" and "Columns:" with the value "1". At the bottom right, there are four buttons: "< Back", "Next >", "Finish", and "Cancel".

6. Edit the side edges, then click “Next”.

The screenshot shows a software dialog box titled "New Document Wizard" with a close button (X) in the top right corner. The main heading is "Side Edges" with the instruction "Specify the characteristics of the sides of your media." Below this, a question asks: "Does your stock have a small amount of unused material between the edge of the item and the edge of the page?" There are two radio button options: "Yes, it does have some unused material on the sides" (which is selected) and "No, it does not". Underneath, the "Width of Unused Area:" is specified with two input fields: "Left: 0.05 in" and "Right: 0.05 in". To the right of these options is a "Preview:" window showing a white rectangular area with rounded corners, surrounded by a blue border that represents the unused material. Below the preview, it says "Template Size: 1.998 x 2 in". At the bottom of the dialog, there are four buttons: "< Back", "Next >" (highlighted in blue), "Finish", and "Cancel".

7. Choose the item shape, then click “Next”.

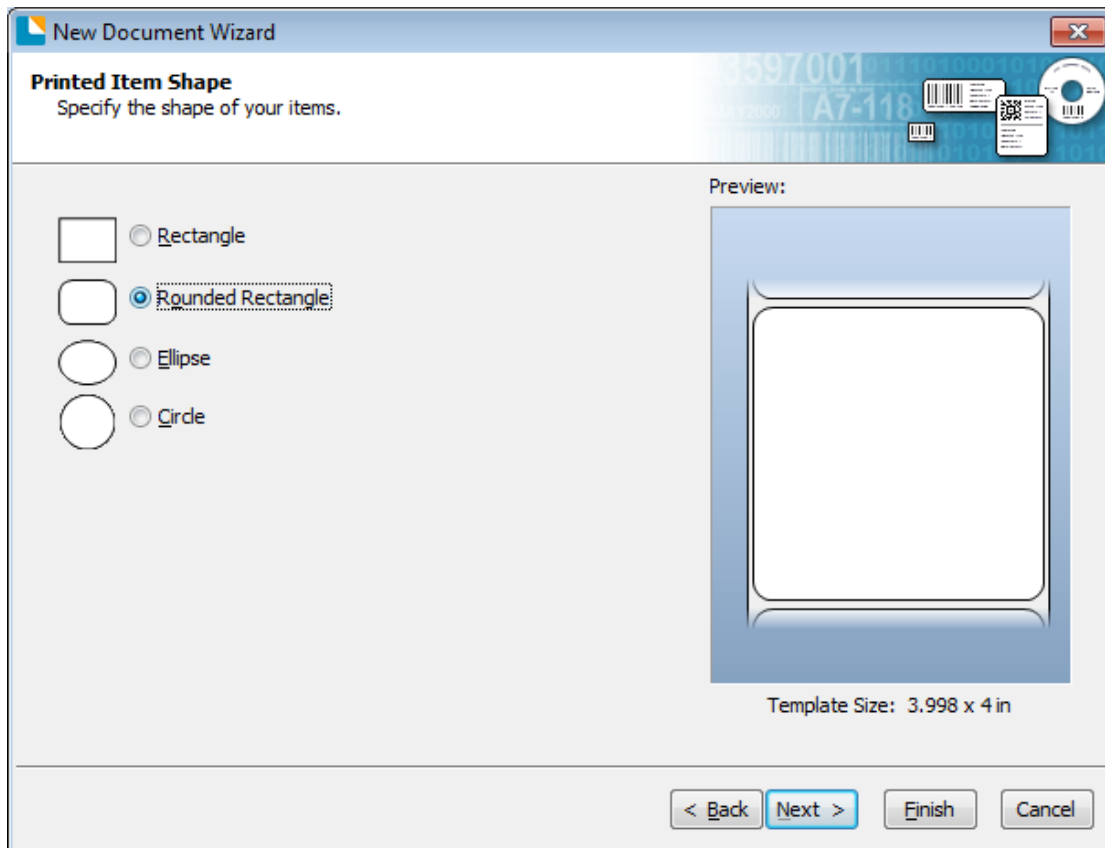

8. Edit the template size, then click "Next".

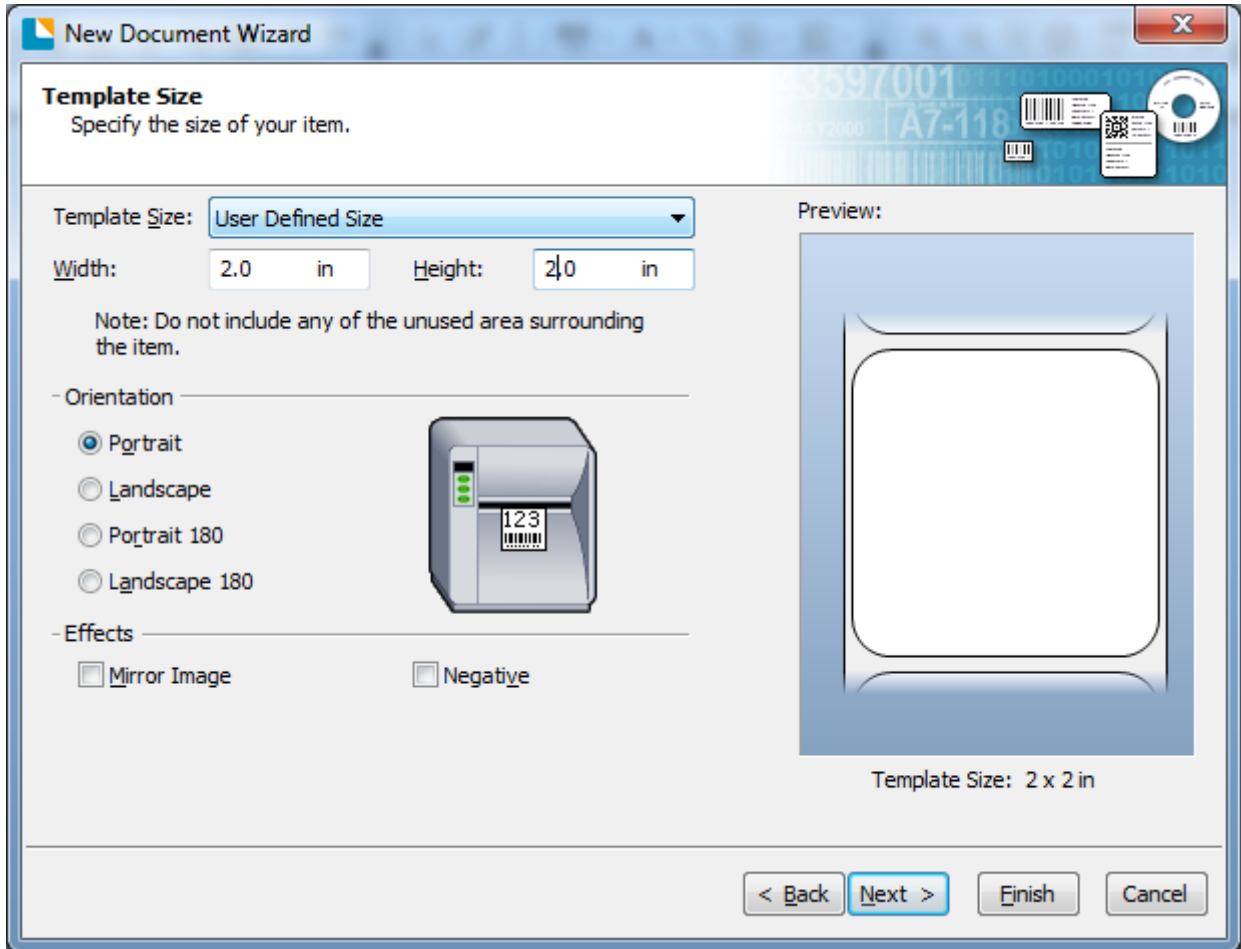

9. Based on your need, edit the template background. Then click “Next”.

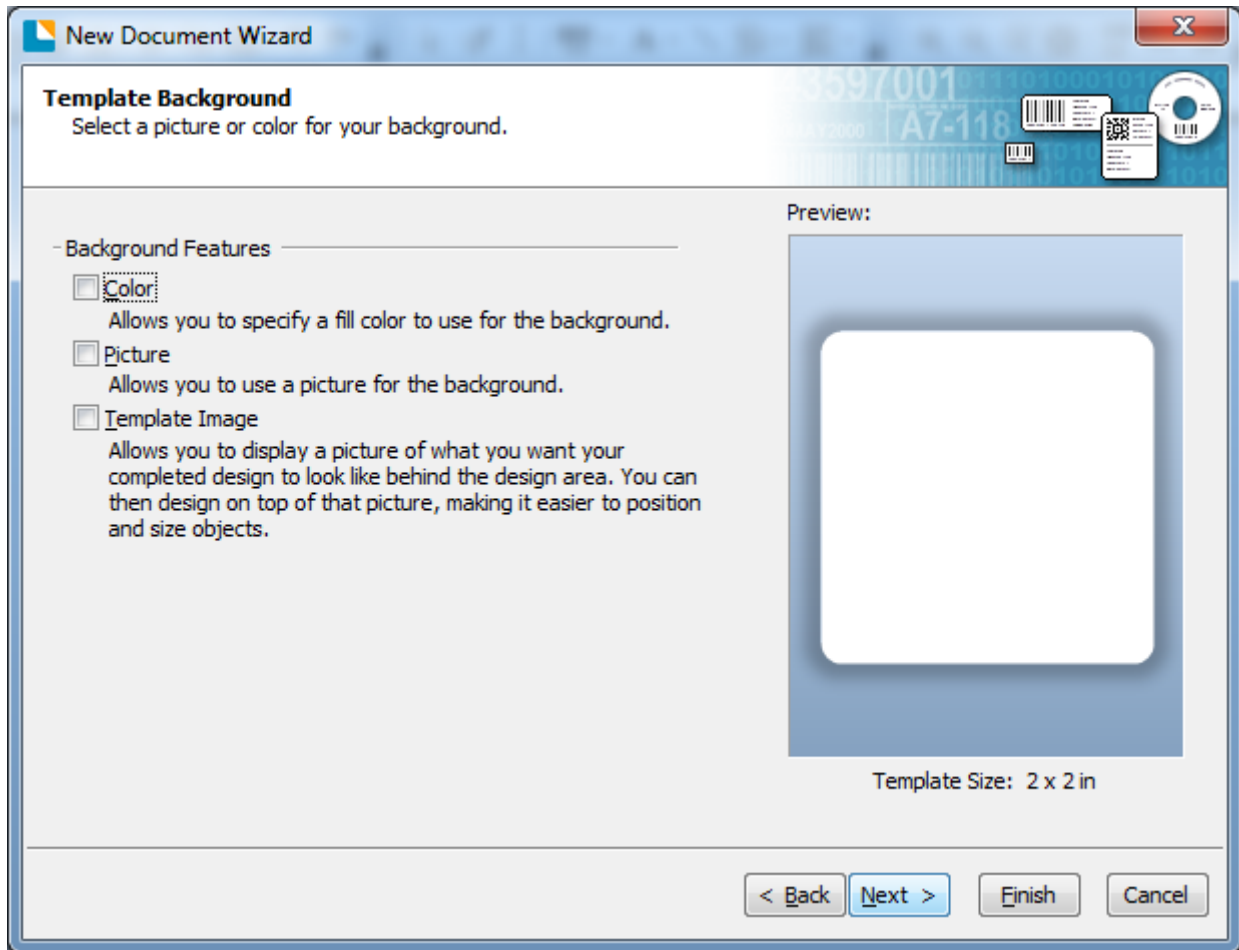



10. Finish the settings, showed in the “Review” and “Preview”. Then click “Finish”.

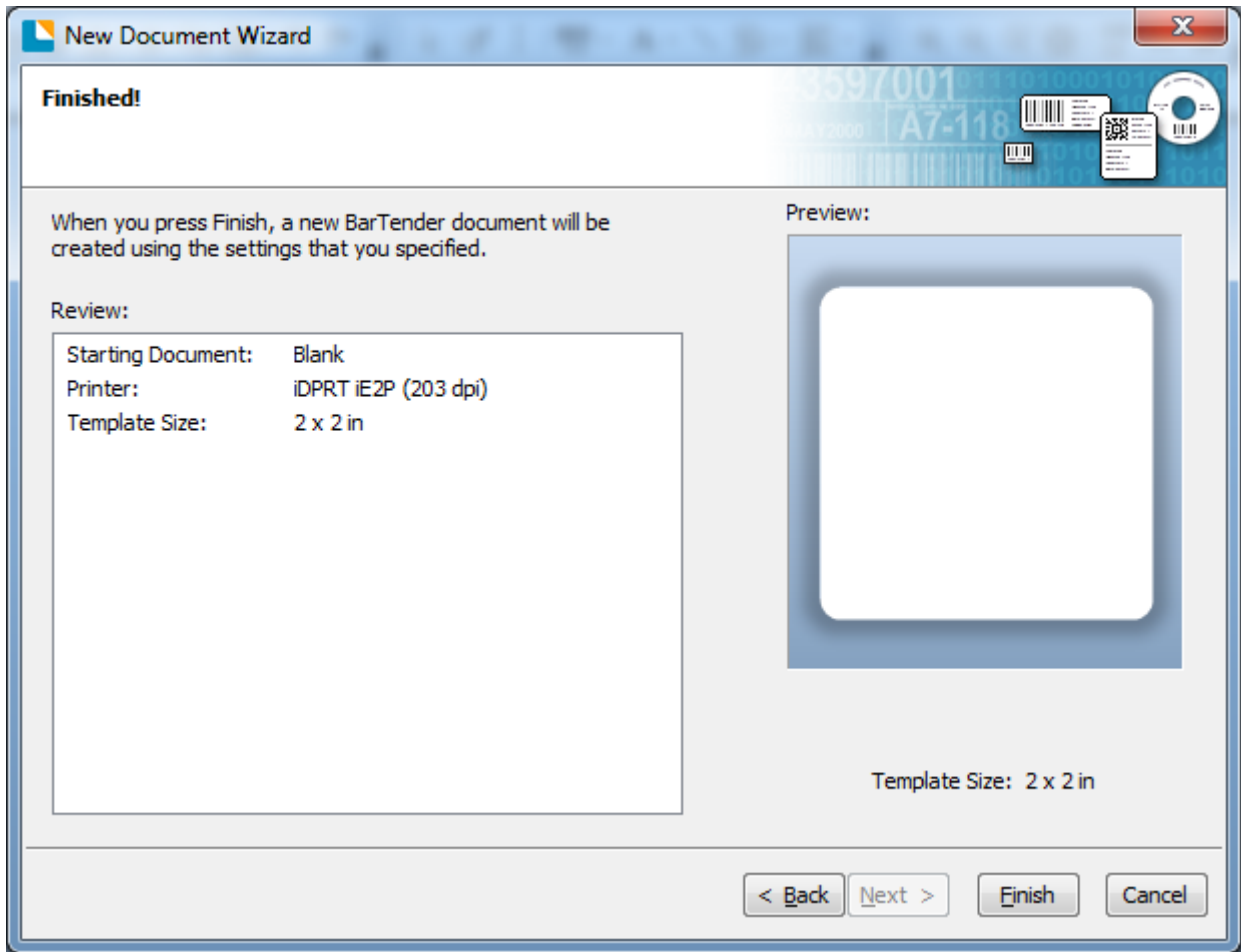

## 8.4.2 label Edit

1. Click the icon of code .
2. Choose the code, then click "Select".

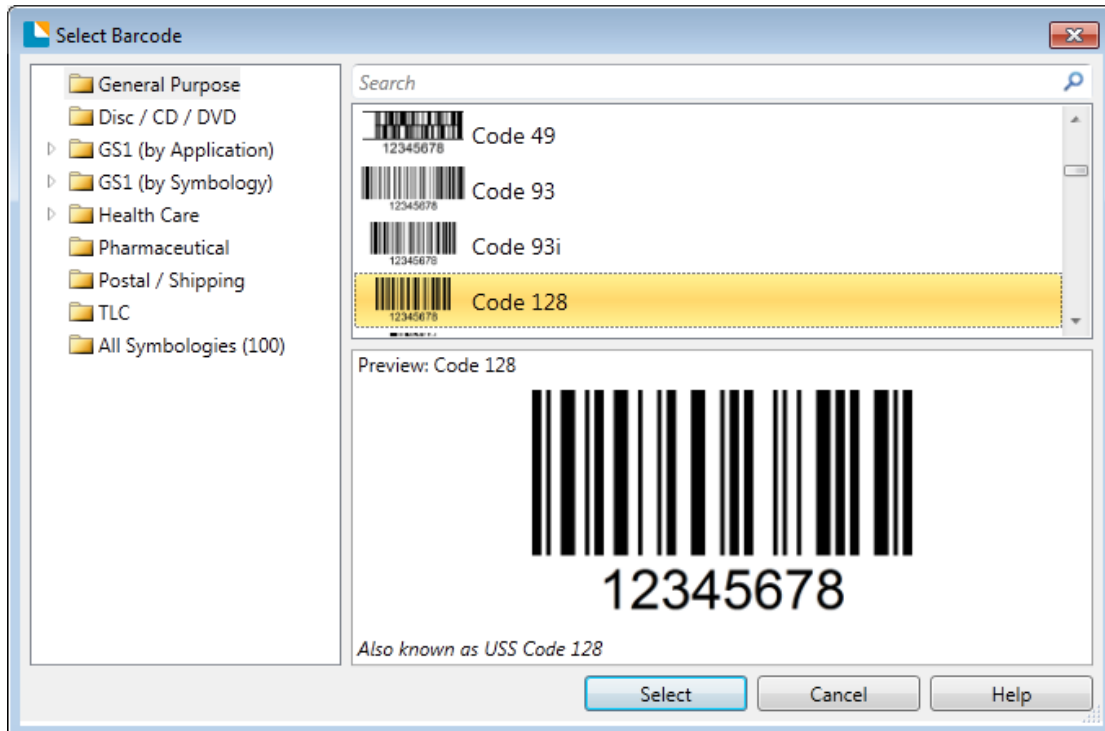

3. Click the blank, showing the code.



4. Double click the code and edit it. User can set up the size, font, border and so on.

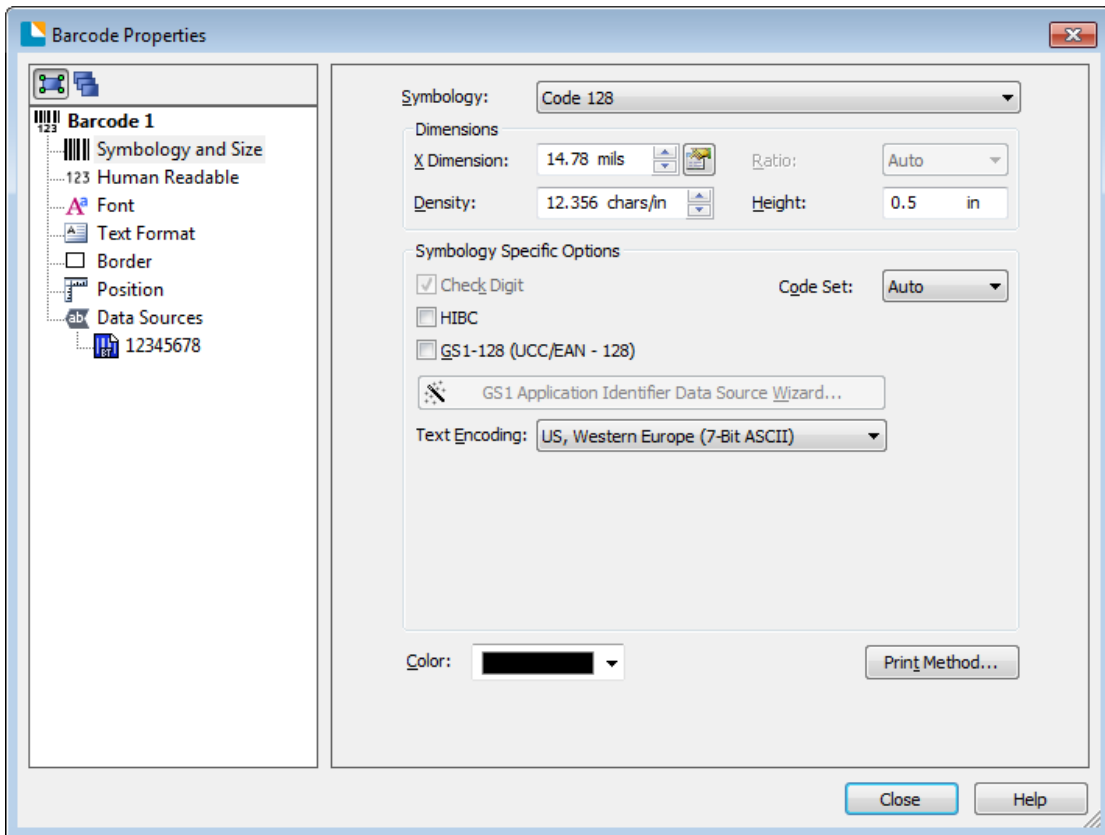

5. Click the icon of character , then enter the text.



6. Click the icon of picture , then edit the pictures.









7. Compose the text.







8. Finish all the settings. Click “Print” and a new label will be printed.





## Appendix I Display Operation

Main menu	Submenu	Parameter	Remark
Setting 	Printing Setup 	Printing Method	0: DT 1: TT Default: Factory settings (locked/unlocked))
		Printing Speed	2-N ips N: Maximum depends on the language Default: Factory settings
		Printing Darkness	0-N ZPL/DPL/=30; EPL=20; TSPL=15 (locked/unlocked)) Default: Factory settings N: Maximum depends on the language
		Page Rotation	0: 0°, 1: 90° 2: 180°, 3: 270° Default:0 (locked/unlocked)
		After Printed	0: None, 1: Tear 2: peeler, 3: Cutter Default:1 (locked/unlocked)
		Stop Position	Position peel, tear and cutter position 0: Automatic default 1: manual 0 - 30.0 mm Default: Tear paper line position based on print line (locked/unlocked)
	Advance 	Label type	0: gap label (default) 1: Black label 2: Continuous paper Default:0 (locked/unlocked)
		Position	0: Automatic (default) 1: Transmissive detection 2: Reflective detection Default:0 (locked/unlocked)
		Print Y offset	Adjust the vertical coordinates of the print start position +/- 120 dots Default:0 (locked/unlocked)
		Print X offset	Adjust the horizontal start of the print +/- 120 dots Default:0 (locked/unlocked)



Main menu	Submenu	Parameter	Remark
Setting  Setting	Advance  Label Setup	PL Simulation Automatic recognition switch 0: ZPL 1: TSPL 2: DPL	Default:0 (locked/unlocked)
		Codepage 0: CP850 1: CP852 2: CP437 3: CP860 4: CP863 5: CP865 6: CP857 7: CP861 8: CP862 9: CP855 10: CP866 11: CP737 12: CP851 13: CP869 14: Win 1252 15: Win 1250 16: Win 1251 17: Win 1253 18: Win 1254 19: Win 1255 20: Win 1257 21: UTF-8 22: UTF-16BE 23: UTF-16LE	Default:0 (locked/unlocked)
Setting  Setting	LCD Setup  LCD Setup	LCD Timeout 0: No 1: 10s-9: 90s	Default:1
		LCD Brightness 0-9	Default:4
		Security Password 0000	Default: 0000 N: 0-9 NNNN: 0000 none password
		Standby Display 0: Display Ready 1: Display date and time	Default: 0



Main menu	Submenu	Parameter	Remark
Setting 	LCD Setup 	LCD Language	0: English 1: Spanish 2: Portuguese 3: France 4: German 5: Ukrainian 6: 日本語 7: 中文简体 8: 中文繁体 9: Download Free Default: 0
		RS232 Setup 	Baud Rate
	Data Bits		1: 7-bit 2: 8-bit Default:1
	Parity Check		0: None 1: Odd 2: Even Default:0
	Flow Control		0: None, 1: XON/XOFF 2: Hardware 3: SW+HW Default:2
	Setting 	Ethernet Setup 	Ethernet Switch
Address Mode			0: DHCP 1: Static Default:1
IP Address			NNN.NNN.NNN.NNN N: 0-9; NNN: 0-255 Default:192.168.1.1
Default Gateway			NNN.NNN.NNN.NNN N: 0-9; NNN: 0-255 Default:192.168.1.0
Subnet Mask			NNN.NNN.NNN.NNN N: 0-9; NNN: 0-255 Default: 255.255.255.0
Port Number			NNNNN N: 0-9 Default:9100

Main menu	Submenu	Parameter	Remark	
Setting 	Wireless Setup 	WiFi Switch	0: OFF 1: ON Default:0	
		Networking Mode	0: AP mode 1: Station mode Default:0	
		SSID	Alphanumeric character AP Default: Printer model	
		Bluetooth Switch	0: OFF 1: ON Default:0	
		Pair Password	NNNN Default:0000 N: 0-9	
	Ext. Device 	Keyboard	Connect port 0: No 1: USB Host (Auto connection) 2: Serial port Default:0	
		Ext. Keyboard Language	0: English 1: Español 2: Português 3: Français 4: Deutsch 5: Русская Default:0	
		Barcode Scanner	Connect port 0: No 1: USB Host (Automatic connection) Default:0	
		Ext. USB	0: NO 1: YES Default:0	
		Int.Device 	Buzzer Volume	0-3 Default: 2
			Date	YYYY/MM/DD
	Time		hh:mm:ss	

Main menu	Submenu	Parameter	Remark
Maintain and Test  	TPH printed mileage	Show printer print miles 0-99999.99 meters	No blank paper miles
	TPH bad dot printing test	Print test sheet	
	TPH bad dot automatically test	Print head impedance anomaly scan test	
	Label Calibration	Label learning and correction:  Action completion will stop in the corresponding stop position according to the setting of the tearing/peeling/cutting	
	Media detection continuous printing	Signal quantitative waveforms detected by print media	Detection according to specified sensor
	Dump mode	Print the received data and automatically change lines when the width of the label exceeds	Press feed button back to standby
	Cutting test	Test the cutter function	Errors will be reported
	Restore factory default	Is there a need to restore Factor sets? Y/N 0: NO 1: YES, Files that have been downloaded and stored will also be retained and not cleaned up	Default: 0
	Firmware update	Automatically list firmware files, select files and confirm whether to read the firmware specified in the U disk for updates? 0: Printer firmware 1: Display Firmware 2: Display Picture Pack 3: Display screen specific page	Default: 0
	Touch screen calibration	Five-point calibration at four corners plus center points	

Main menu		Parameter	Remark
Config Info  Config Info	Printer settings information	Print out the current printer settings information	
	Built-in glyph list	Print out all built-in glyph models	
	built-in barcodes list	Print out all barcode models	
	List of user flash files	Print a list of user flash files	
	List of user memory files	Print a list of user memory files	
	LCD Configuration	System: XX Version: XX Title: XX	
Smart Printing  Smart Printing	File Management	List display/copy/delete/start label format printing on specified memory/picture/font/database/firmware I: \.. (Internal Flash) U: \iDPRT\... (External USB Storage)	Default: list
	Auto Form	The selected label format runs automatically after the printer is turned on 0: No 1: Yes	Default: 0

## Appendix II Warning

Problem	Solution
Form is not found	Check if the files are exactly stored in the memory device.
Image is not found	Check if the image is exactly stored in the memory device.
Fonts is not found	Check if the font is exactly stored in the memory device.
No F/W found	Firmware files are not stored in the USB storage when updating the firmware.
No Battery Found	Battery is not installed in the printer when setting time and date. Check if the battery power runs out or not installed well.
Password Error	Wrong password is entered. Enter the correct password to modify the protected parameters.
USB storage Lock	Printer cannot write the data to the USB storage. Unlock the USB storage.
No USB storage found	There is no USB storage installed in printer when updating the printer. Check if the USB storage is well inserted in printer.
No Cutter Found	Cutter is not installed on printer when execute the cutter test.
Ethernet Error	Ethernet port is disconnecting.
Flash ROM Full	Internal flash ROM is full. Delete un-necessary files to store the current files.
Found No Bluetooth	There is no Bluetooth module installed in the printer.
Found No WiFi	There is no WiFi module installed in the printer.
Material too thick	Material is too thick or hard, cutter takes longer time to return the blade to the initial position after cut.

## Appendix III Trouble Shooting

Error	Resolution
Found no Gap Label	<ol style="list-style-type: none"> <li>1.Ensure the see-through sensor type is selected correctly.</li> <li>2.Adjust the media sensor box to correct position.</li> <li>3. Clean the receiver sensor and emitter sensor.</li> <li>4. Ensure the label gap size is not out of from 2mm to 15mm.</li> <li>5. Use “Media Sensor Printing” to verify the sensing signal from the media.</li> </ol>
Found no Black Mark	<ol style="list-style-type: none"> <li>1.Ensure the reflective sensor type is selected correctly</li> <li>2.Adjust the media sensor box to correct position</li> <li>3.Black Mark height range: 3mm-30mm. Width minimum 10mm</li> <li>4.Use “Media Sensor Printing” to verify the sensing signal from the media</li> </ol>
Paper Out	Reload new media roll.
Ribbon Out	Reload new ribbon roll.
Ribbon Steady	Remove the ribbon or configure the printer for thermal transfer media.
Print Head Open	Close the printer cover.
Firmware Update Fail	Re-update the firmware.
TPH Fail	Replace a new TPH.
Command Error	Press Feed key to clear this error, and make sure the next input commands are supported by the printer.
Cutter Jam	Check if labels stick in cutter and then clear up the adhesive from cutter bled.
Print Head is over-heat	Just wait for the TPH cool down and then continue printing automatically.
Write error	Ensure the mass storage is installed and formatted properly.
Write protected	Ensure the write protection is disable from the mass storage.
Paper Jam	Clear the jammed paper from the paper through path.

## Appendix IV Download Path for Utility and Driver

1. Enter the website in browser: <http://www.idprt.com>
2. Select the “DOWNLOAD” to get the Utility and Driver.



## FCC-DECLARATION OF CONFORMITY

Product

We, Xiamen Hanin Electronic Technology Co., Ltd. declare that the product conforms to the following specification: FCC Part 15, Subpart B Class A digital device.

This device complies with Part 15 of the FCC rules. Operation is subject to the following Two Conditions:

- This device may not cause harmful interference;
- This device must accept any interference received, including interference that may cause undesired operation.
- The user is cautioned that any changes or modification not expressly approved in this manual could void the user's authority to operate the equipment. To ensure compliance, this printer must be used with shielded communication cables.
- Use only power supplies listed in this manual and /or recommended and approved in this manual.



## EC DECLARATION OF CONFORMITY

Manufacturer certifies that the following designated product

Type of product

Thermal Transfer label/Direct Thermal Label Printer

It is in conformity with the standards

*Test standard information*

Under the Council Directive: (LVD) Directive 2014/35/EU relating to electrical equipment designed for use within Low Voltage Directive.

EN 60950-1:2006+A11:2009+A1:2010+A12:2011+A2:2013

Under the Council Directive: (EMC) Directive 2014/30/EU relating to Electro Magnetic Compatibility.

EN 55032:2015

EN 55024:2010

EN 61000-3-2:2014

EN 61000-3-3:2013

We declare herewith that as a result of the way in which the device designated below was designed, the type of construction and the devices which, as a result have been brought on to the general market comply with the relevant fundamental regulations of the EC Rules for Safety. And we declare herewith the below mentioned model is conformity with Directive 2014/30/EU and 2014/35/EU. In the event of any alteration which has not been approved by us being made to any device as designated below, this statement shall thereby be made invalid.

The declaration is sole responsibility of the manufacturer

*Name of manufacturer*

Xiamen Hanin Electronic Technology Co., Ltd.



Please refer to the attachment for details of FCC certification.